

ABB solar inverters

# Product manual

## PVI-10-12-I-OUTD-(X)-US/CAN (10 to 12 kW)





## **IMPORTANT SAFETY INSTRUCTIONS**

*This manual contains important safety instructions that must be followed during installation and maintenance of the inverter.*



## **SAVE THESE INSTRUCTIONS!**

*Keep this document in a safe place near the inverter for easy access during installation and maintenance.*



## **THE INSTALLER MUST READ THIS DOCUMENT IN ITS ENTIRETY BEFORE INSTALLING OR COMMISSIONING THIS EQUIPMENT.**

*The purpose of this document is to support the qualified technician, who has received training and/or has demonstrated skills and knowledge in construction, to install and maintain this inverter. This manual does not cover any details concerning equipment connected to the inverter such as the solar modules. Information concerning the connected equipment is available from the respective manufacturers.*

*Warranty conditions can be found on the TRIO product page of the website. NOTE: Any changes or modifications not approved by the responsible party could void the user authority to operate the equipment.*

## **FCC REMARKS**



*The equipment has been tested and found to comply with the limits for a Class B digital device, pursuant to Part 15 of the FCC Rules. These limits are designed to provide reasonable protection against harmful interference in a residential installation. This equipment generates, uses and can radiate radio frequency energy and, if not installed and used in accordance with the instructions, may cause harmful interference to radio communications.*

*However, there is no guarantee that interference will not occur in a particular installation. If this equipment does cause harmful interference to radio or television reception, which can be determined by turning the equipment off and on, the user is encouraged to try to correct the interference by one or more of the following measures:*

- *Reorient or relocate the receiving antenna.*
- *Increase the separation between the equipment and receiver.*
- *Connect the equipment into an outlet on a circuit different from that to which the receiver is connected.*
- *Consult the dealer or an experienced radio/TV technician for help.*

---

## Product Manual

### PVI-10-12 string inverters

1 - Introduction and safety



2 - Installation



3 - Wiring



4 - Operations



5 - Troubleshooting



6 - Maintenance



7 - Appendix



# Contents

<b>Introduction and safety</b> .....	<b>7</b>
Warnings in this document .....	7
Equipment safety warnings.....	7
General installation warnings.....	8
Assembly warnings .....	8
Electrical connection warnings.....	8
Safety instructions .....	9
General information.....	9
Thermal and voltage hazard .....	9
Clothing and protective devices .....	10
Location of safety notices and labels.....	10
Appropriate usage.....	10
Conditions of use.....	10
Environmental conditions.....	10
Improper or prohibited use.....	10
Available versions .....	11
Product label .....	12
Regulatory nameplate .....	13
<b>Installation</b> .....	<b>15</b>
Transportation and handling.....	15
Lifting .....	15
Incoming inspection.....	15
Select the installation location.....	17
Environmental check.....	17
Installation position .....	18
Wall mounting .....	19
Mounting PVI-10/12-I-OUTD-(S1, S2).....	20
Mounting PVI-10/12-I-OUTD no switchbox version .....	21
<b>Wiring</b> .....	<b>23</b>
Preparing to connect the inverter.....	23
Wiring details .....	24
Inverter connection board - all versions .....	24
Switchbox components .....	25
Conduit and knockout details.....	26
Conduit and knockout details PVI-10/12-I-OUTD .....	26
Conduit and knockout details PVI-10/12-I-OUTD-S1 .....	26
Conduit and knockout details PVI-10/12-I-OUTD-S2 .....	27
Removing front covers.....	27
Preliminary connection details .....	28
Typical connections PVI-10/12-I-OUTD.....	28
Typical connections PVI-10/12-I-OUTD-S1 .....	29
Typical connections PVI-10/12-I-OUTD-S2.....	29
Independent or parallel configuration of dual inputs.....	30
Inmode switch S1.....	30
Parallel mode PVI-10/12-I-OUTD.....	30
Parallel mode PVI-10.0/12.0-I-OUTD-(S1, S2).....	31

DC array connections .....	34
DC array connections PVI-10/12-I-OUTD.....	34
DC array connections PVI-10/12-I-OUTD-(S1, S2).....	35
AC grid connections .....	36
Grid-type configuration 3PHMOD switch.....	36
AC grid connections PVI-10/12-I-OUTD.....	36
AC grid connections PVI-10/12-I-OUTD-(S1, S2).....	37
Setting the grid/country standard and language .....	38
Communication and signal connections.....	38
Serial communication connection (RS-485).....	39
Daisy chain units for connection to a monitoring system.....	40
Addressing each inverter.....	41
Monitoring system via serial (RS-485).....	41
Configurable relay connection (Alarm).....	41
Remote control connection .....	42
<b>Operations</b> .....	<b>43</b>
Monitoring and data transmission .....	43
Types of data available .....	43
User interface .....	43
LED indicators.....	45
Commissioning.....	46
Connection of system to the grid .....	46
First phase - electric parameter monitoring .....	48
Description of the menus .....	49
Statistics menu .....	49
Settings menu .....	51
Information menu.....	57
<b>Troubleshooting</b> .....	<b>59</b>
Display messages and error codes .....	59
Making a service call.....	72
<b>Maintenance</b> .....	<b>73</b>
Shut-down procedure .....	73
Routine maintenance .....	73
Ground fault detector fuse replacement.....	74
Storage and dismantling .....	75
<b>Appendix</b> .....	<b>77</b>
System description .....	77
Protective devices within the inverter.....	78
Block diagram.....	78
Block diagram of PVI-10.0-I-OUTD.....	79
Block diagram of PVI-12.0-I-OUTD.....	79
Efficiency curves .....	80
Power derating curves.....	80
Technical data and types PVI-10-I-OUTD.....	82
Technical data and types PVI-12-I-OUTD.....	83

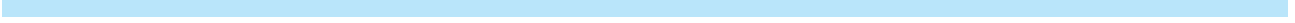





## Introduction and safety

# 1

### Warnings in this document

This is a list of special safety symbols used in this manual that highlight potential safety risks and/or useful information. The symbol usage is described below:

---





	<b>CAUTION</b> The reader should stop, use caution and fully understand the operations explained before proceeding.
	<b>DANGEROUS VOLTAGE</b> The product works with high voltages. All work on the inverter must follow the described documentation and must comply with all prevailing codes and regulations associated with high voltages.
	<b>HOT TEMPERATURE</b> Some surfaces may become hot; do not touch the product while it is in operation.
	UL1741 Standard for Safety for Inverters, Converters, Controllers and Inter-connection System Equipment for use with Distributed Energy Resources. CSA-C22.2 No. 107.1-01 - General Use Power Supplies.

---

### Equipment safety warnings

In addition to the safety and hazard symbols, the following symbols are also used in this installation guide.

---

	System earth conductor (equipment ground, protective earth)
	Alternating current (AC)
	Direct current (DC)
	Phase
	Grounding (earth)

---

## General installation warnings

The inverter is designed and tested according to international safety requirements (UL1741/IEEE1547); however, certain safety precautions must be observed when installing and operating this inverter. Read and follow all instructions, cautions and warnings in this installation manual.



**All operations regarding transport, installation start up, and maintenance, must be carried out by qualified, trained personnel and in compliance with all prevailing local codes and regulations.**

## Assembly warnings

Prior to installation, inspect the unit to ensure absence of any transport or handling damage, which could affect insulation integrity or safety clearances; the failure to do so could result in safety hazards.

Assemble the inverter per the instructions in this manual. Use care when choosing the installation location and adhere to specified cooling requirements.

Unauthorized removal of necessary protection features, improper use, incorrect installation or operation may lead to serious safety and shock hazards and/or equipment damage.

## Electrical connection warnings

This grid-tied inverter system operates only when properly connected to the AC utility grid. Before connecting the grid-tied inverter to the AC utility grid, contact the local power distribution company to receive the appropriate approvals. This connection must be made only by qualified technical personnel.



**Wiring methods used should be in accordance with the National Electric Code, ANSI/NFPA 70 and/or any prevailing local codes and regulations.**

**Output circuits must be isolated from the enclosure. System grounding, required by Sections 690.41 - 690.43 of the National Electric Code, ANSI/NFPA 70, is the responsibility of the installer.**



**The inverter should be connected only to a dedicated branch circuit. For models that do not include AC output overcurrent protection, it is the responsibility of the end user to provide protection for the AC output circuit.**

**Connect only to a circuit provided with the maximum branch OCPD in accordance with the CSA document available on the website and listed in the technical data table of the Appendix, part 7.**



## Safety instructions

These servicing instructions are for use by qualified personnel only. To reduce the risk of electric shock, do not perform any servicing other than that specified in the operating instructions.

Be sure all flammable materials including construction items are away from the unit. Do not install the inverter in or near potentially explosive areas.

The installer and/or operator must properly protect the installation from access by the public and/or highlight with signs or notices the potential hazards of the equipment, e.g., magnetic fields, hazardous voltages, high temperatures, possibility of discharges, generic hazard, etc.

Install the inverter in accordance with the electrical standards prescribed by the applicable National Electric Code (NEC), and/or by other local codes and regulations.



## General information

The equipment has been manufactured in accordance with the strictest accident-prevention regulations and supplied with safety devices suitable for the protection of components and operators. Inform ABB about non-standard installation conditions.

It is essential to provide operators with correct information. They must read and comply with the technical information given in the manual and any other attached documentation.

The instructions given in the manual do not replace the information and warnings on the safety labels mounted on the product. They do not replace the safety regulations enforced in the country of installation and common sense rules.

Maintenance operations must be carried out according to the Maintenance section in Part 6 of this manual. Do not use the equipment if any operating anomalies are found. Liabilities arising from commercial components are delegated to their respective manufacturers.

## Thermal and voltage hazard



**Depending upon ambient temperatures during operation and immediately following shut down, surface temperatures on the cooling fins (heat sink) and some areas of the chassis may be extremely hot to the touch.**

Prior to touching any part of the inverter use care to ensure surfaces and equipment are at touch-safe temperatures and voltages before proceeding.

Anytime the inverter has been disconnected from the AC utility grid, use extreme caution as some components can retain charge sufficient to create a shock hazard and may need time to dissipate the charge. To minimize occurrence of such conditions, comply with all corresponding safety symbols and markings present on the unit and in this manual.

## Clothing and protective devices

Appropriate personal protective equipment (PPE) must be worn at all times when servicing this equipment under any conditions which may subject personnel to hazardous voltages or temperatures that are not touch-safe.

All operations on the equipment should be performed with properly electrically insulated instruments.

## Location of safety notices and labels

Note the location of safety notices on the inverter for notification and protection. Labels must not be hidden with external objects or parts such as rags, boxes, or other such equipment. They should be cleaned periodically and always maintained in view.

## Appropriate usage

The inverter is a photovoltaic inverter that converts direct current of a connected PV array into alternating current and feeds that power into the AC utility grid.

This inverter is designed for outdoor use, but can be used indoors if installed to specified environmental and mounting parameters stated in this manual, and adherence to the National Electric Code. (See Environmental Conditions below and Environmental Checks in part 2.

## Conditions of use

The DC and AC operating currents **MUST NOT** exceed the limits documented in the technical specifications.

The inverter is certified for use only with photovoltaic arrays connected to its input channel(s). Do not connect batteries or other types of power sources.

The inverter can only be used if all the technical requirements in this manual are observed and applied.

## Environmental conditions

Adverse environmental conditions can lead to a reduction in performance. The equipment should be installed outdoors, but only in environmental conditions indicated in this manual. Care must be taken to provide adequate ventilation if installed indoors.

## Improper or prohibited use

The following actions are dangerous and not consistent with acceptable practice under the terms of the warranty:

- Installing the equipment in environments with flammable conditions.
- Using the equipment with safety devices not working or disabled.
- Using the equipment or parts of the equipment by connecting it to other machines or

- equipment, unless otherwise expressed.
- Modifying areas that are operator restricted and/or altering parts of the equipment in order to vary the performance or change its protection.
- Cleaning with corrosive products that may corrode parts of the equipment or with products that might generate electrostatic charges.
- Using or installing the equipment or parts of it without having read and correctly interpreted the contents of this manual.
- Blocking airflow to the cooling fins (e.g., warming or drying rags) on the unit or accessory parts is dangerous and could compromise the inverter operation.



## Available versions

The inverters can be divided into two groups according to their rated output power of 10kW or 12kW. For inverters of equal output power, the differences between models are the configurations of the wiring box. A description of the wiring box configurations available can be found in the table below.

### Wiring box configurations available

PVI-10.0/12.0-I-OUTD-US/CAN-XXX-YY 28.2”H x 25.4” x 8.7”D/ 716mm x 645mm x 222mm 101 lb./45.8 kg	Model does not have a switchbox or integrated disconnect switches; requires external customer supplied switches.
PVI-10.0/12.0-I-OUTD-S1-US/CAN-XXX-YY –S1 Version w/DC switchbox 37.7”H x 25.4”W x 8.7”D/ 958mm x 645mm x 222mm 107 lb./48.5 kg	Model has a large switchbox with an integrated DC switch and dual 3-string fused combiners.
PVI-10.0/12.0-I-OUTD-S2-US/CAN-XXX-YY -S2 Version w/DC and AC switchbox 37.7”H x 25.4”W x 8.7”D/ 958mm x 645mm x 222mm 114 lb./51.7kg	Model has a large switchbox with integrated DC and AC disconnect switches, and dual 3-string fused combiners.

There are three grid-voltage options:

1. The 208 models are for connection to a 208VRMS/3Ø 3-wire or 4-wire distribution grid
2. The 480 models are for connection to a 480VRMS/3Ø/4W grid (Neutral required)
3. The 600 models are for connection to a 600VRMS/3Ø/3-wire or 4-wire distribution grid



**Typically, the inverter is connected with the same number of wires as the distribution system. If connecting to a Y grid, use four wires (three phase conductors and neutral conductor).**

The part numbers of available versions are listed in the table below.





**Part numbers of available versions**

10kW Models		
10kW/no switchbox	10kW/DC switchbox	10kW/DC+AC switchbox
PVI-10.0-I-OUTD-US-208	PVI-10.0-I-OUTD-S1-US-208	PVI-10.0-I-OUTD-S2-US-208
PVI-10.0-I-OUTD-CAN-208	PVI-10.0-I-OUTD-S1-CAN-208	PVI-10.0-I-OUTD-S2-CAN-208
PVI-10.0-I-OUTD-US-480	PVI-10.0-I-OUTD-S1-US-480	PVI-10.0-I-OUTD-S2-US-480
PVI-10.0-I-OUTD-CAN-480	PVI-10.0-I-OUTD-S1-CAN-480	PVI-10.0-I-OUTD-S2-CAN-480
PVI-10.0-I-OUTD-CAN-600	PVI-10.0-I-OUTD-S1-CAN-600	PVI-10.0-I-OUTD-S2-CAN-600
12kW Models		
12kW/no switchbox	12kW/DC switchbox	12kW/DC+AC switchbox
PVI-12.0-I-OUTD-US-480	PVI-12.0-I-OUTD-S1-US-480	PVI-12.0-I-OUTD-S2-US-480
PVI-12.0-I-OUTD-CAN-600	PVI-12.0-I-OUTD-S1-CAN-600	PVI-12.0-I-OUTD-S2-CAN-600



## Product label

The sample product shown is affixed to the inverter and provides the following information:

<p><b>PVI-XX.X-I-OUTD-YYY</b></p>     	<ul style="list-style-type: none"> <li>• <b>Inverter model</b> <ul style="list-style-type: none"> <li>- XX.X = Inverter power rating</li> <li>- YYY = Grid voltage</li> </ul> </li> <li>• <b>Inverter Part Number</b></li> <li>• <b>Week/Year of manufacture</b></li> <li>• <b>Inverter Serial Number</b> composed of:                             <ul style="list-style-type: none"> <li>- YY = Year of manufacture</li> <li>- WW = Week of manufacture</li> <li>- SSSSSS = sequential number</li> </ul> </li> </ul>
---	---

# Regulatory nameplate

The nameplate shown is affixed to the inverter and provides the following information:

- 1. Certification
- 2. Product origin
- 3. Model number
- 4. DC input ratings
- 5. AC output ratings

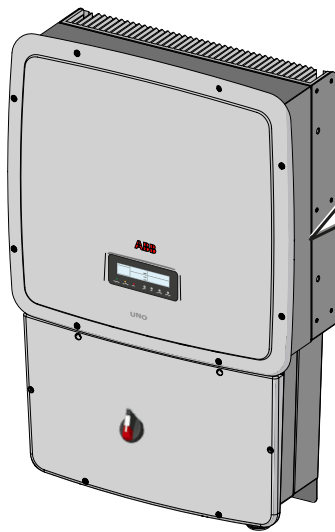

**ABB**

1



C US  
UL 1741  
CSA-C22.2 No. 107.1-01  
Country of Origin Italy

www.abb.com/solar

SOLAR UTILITY INTERACTIVE INVERTER

2

MODEL: PVI-10.0-I-OUTD-S1-US-480-NG

3

**DC RATING 4**

Nominal Input Operating Voltage	320 V $\text{---}$
Max. Input Voltage	520 V $\text{---}$
Range of Input Operating Voltage	90 - 520 V $\text{---}$
Range of Input Voltage @Full Power	220 - 470 V $\text{---}$
Max. Input Current	2 x 24 A
Max. Input Short Circuit Current (P.V. Panels)	2 x 29 A

**AC RATING 5**

Nominal Output Voltage	480 V $\sim$ 3 $\phi$
Operating Voltage Range	422 - 528 V $\sim$
Nominal Output Frequency	60 Hz (factory preset)
Operating Frequency Range	59.3 (1) - 60.5 (2) Hz
Output Power Factor	>0.995
Max. Output Current (for each phase)	14 A (rms)
Max. Continuous Output Power	10000 W @ 40°C amb.
Max. Output Overcurrent Protection	20 A

Operating Ambient Temperature: -25 to +60 °C (-13 to +140 °F), with Output Power Derating  
Type of Enclosure: NEMA 4X

DC Ground Fault Detector/Interrupter is Provided

(1): Adjustable from 57.0 Hz to 59.8 Hz (2): Adjustable from 60.2 Hz to 63.0 Hz

For more details about product specifications refer to the Instruction Manual

This device complies with Part 15 of the FCC Rules. Operation is subject to the following two conditions: (1) this device may not cause harmful interference, and (2) this device must accept any interference received, including interference that may cause undesired operation.





## Transportation and handling

Transportation of the equipment, especially by road, must be carried out by suitable ways and means for protecting the components (in particular, the electronic components) from violent shocks, humidity, vibration, etc. During handling, do not make any sudden or fast movements that can create dangerous swinging.

*During transportation the crated inverters should only be stacked three high.  
For storage purposes, units in their original unopened packaging can be stacked five high on a flat dry surface capable of withstanding the weight.*

*DO NOT stack with equipment or products other than those indicated or store in damaging, corrosive environments.*

## Lifting

ABB packages and protects individual components using suitable means to make their transport and subsequent handling easier. Due to the weight and complexity of this equipment, the process of loading and unloading of this equipment should be done by an experienced or specialized staff knowledgeable in material handling.

Where indicated or where there is a provision, eyebolts or handles can be inserted and used as lifting points. Do not lift several units or parts of the equipment at the same time, unless otherwise indicated.



## Incoming inspection

It is the customer's responsibility to examine the condition of the unit. Upon receipt of the inverter check the following:

- Inspect the shipping container for any external damage.
- Inventory the contents against the table below and verify receipt of all items.
- Use care not to discard any equipment, parts, or manuals.
- Call the delivering carrier if damage or shortage is detected.

If inspection reveals damage to the inverter, contact the supplier or authorized distributor for a repair/return determination and instructions regarding the process.

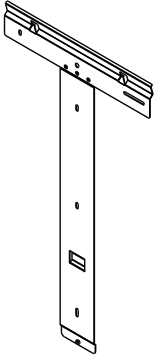
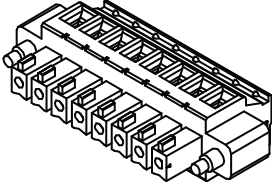
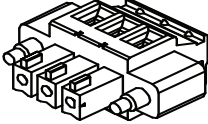

COMPONENTS INCLUDED WITH ALL MODELS	QTY/PART NO.
	<p>(1) Mounting bracket, (4 each) wall anchor, screw, washer, (1) locking screw for securing wiring box to mounting bracket</p> <p>Mounting kit XAK.V0502.0</p>
	<p>8 pin connector</p> <p>2 82000005908-G</p>
	<p>3 pin connector</p> <p>2 82000005907-G</p>
	<p>Torx wrench; 90°; T20; 64x23mm,</p> <p>1 81510000077</p>
	<p>AWG10 cables</p> <p>1 Red 1 Black</p>



## Select the installation location



The inverter must be installed by qualified installers and/or licensed electricians according to the applicable local code regulations (NEC, CEC, and other).

Once physically mounted, the wiring must be carried out with the equipment disconnected from the grid (power disconnect switch open) and the photovoltaic panels shaded or isolated.

## Environmental check



- See technical data in Appendix, part 7 to check the environmental parameters to be observed (degree of protection, temperature, humidity, altitude, etc.).
- The maximum operational ambient air temperature **MUST** be considered when choosing the inverter installation location.
- Installing the inverter where operating temperatures exceed the specifications will result in power derating. It is recommended the inverter be installed within the specified temperature range.
- Exposure to direct sunlight will increase the operational temperature of the inverter and may cause output power limiting. It is recommended to use a sun shade minimizing direct sunlight when the ambient air temperature around the unit exceeds 104°F/40°C.
- Do not install in small closed spaces where air cannot circulate freely.
- Due to acoustical noise (about 50dBA at 1 m) from the inverter, do not install in rooms where people live or where the prolonged presence of people or animals is expected.
- To avoid overheating, always make sure the flow of air around the inverter is not blocked.
- Do not install in places where gases or flammable substances may be present.

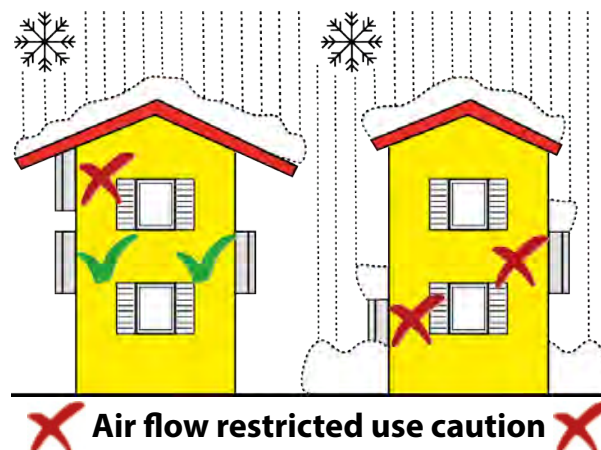
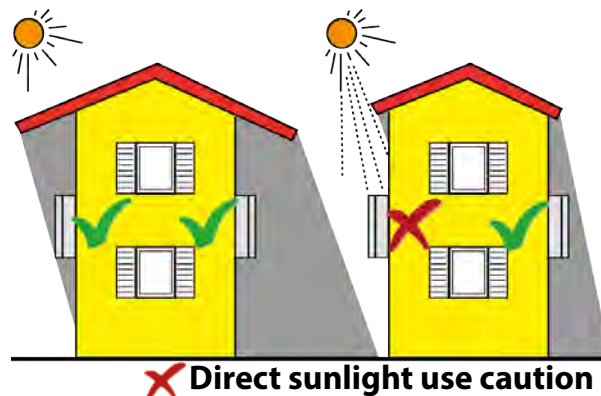

## Installation position

When choosing the installation location and position, comply with the following conditions:

- Install on a wall or strong structure capable of bearing the weight.
- Install vertically with a maximum incline of +/- 5°. If the mounted inverter is tilted to an angle greater than the maximum noted, heat dissipation can be inhibited, and may result in less than expected output power.
- Install in safe place where all switch handles and controls remain easy to reach and meet height requirements of the applicable electrical code. Install at eye level so the display and status LEDs can be easily seen.
- Ensure sufficient working area in front of the inverter to allow removal of the wiring box cover and easy access for servicing the inverter.
- When planning the installation, maintain clearance distances shown to allow normal control functions and easy maintenance operations.

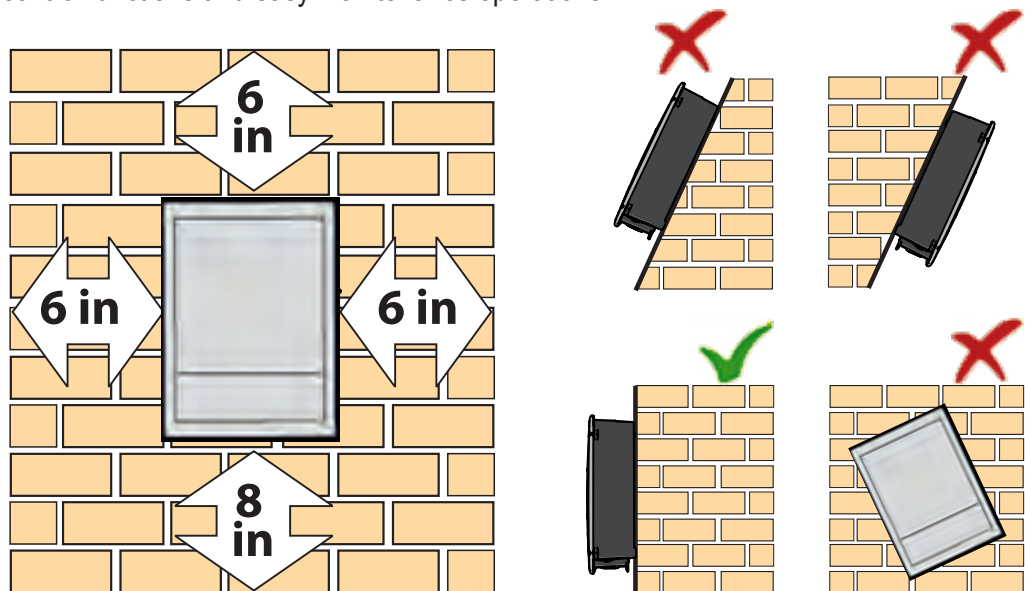

For multiple inverter installations, position the inverters side-by-side, maintaining minimum clearances. If the space available does not allow the side-by-side arrangement, multiple inverters can be placed in a staggered arrangement as shown; this minimizes heat dissipation from lower inverters affecting operation of other inverters.

Minimum clearances illustrated include width of inverter plus additional allowances for inverters arranged above or below.

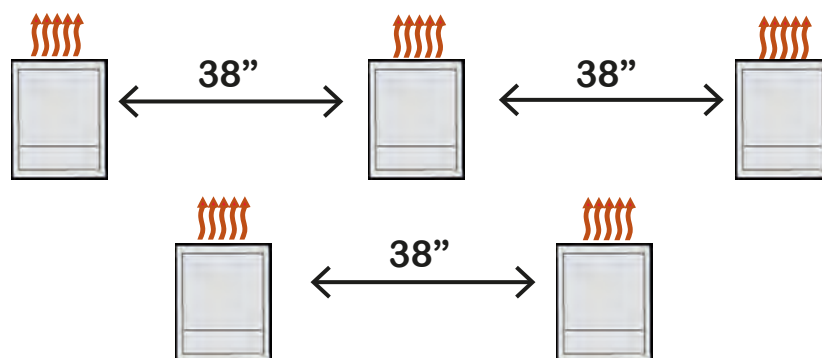

## Wall mounting

Included in the shipping package is a mounting kit with stainless steel screws and wall anchors for mounting the powder coated, stainless steel bracket to a wall or structure.

Mounting bracket for PVI-10/12-I-OUTD-(S1, S2) is shown below; measurements are expressed in millimeters and inches.

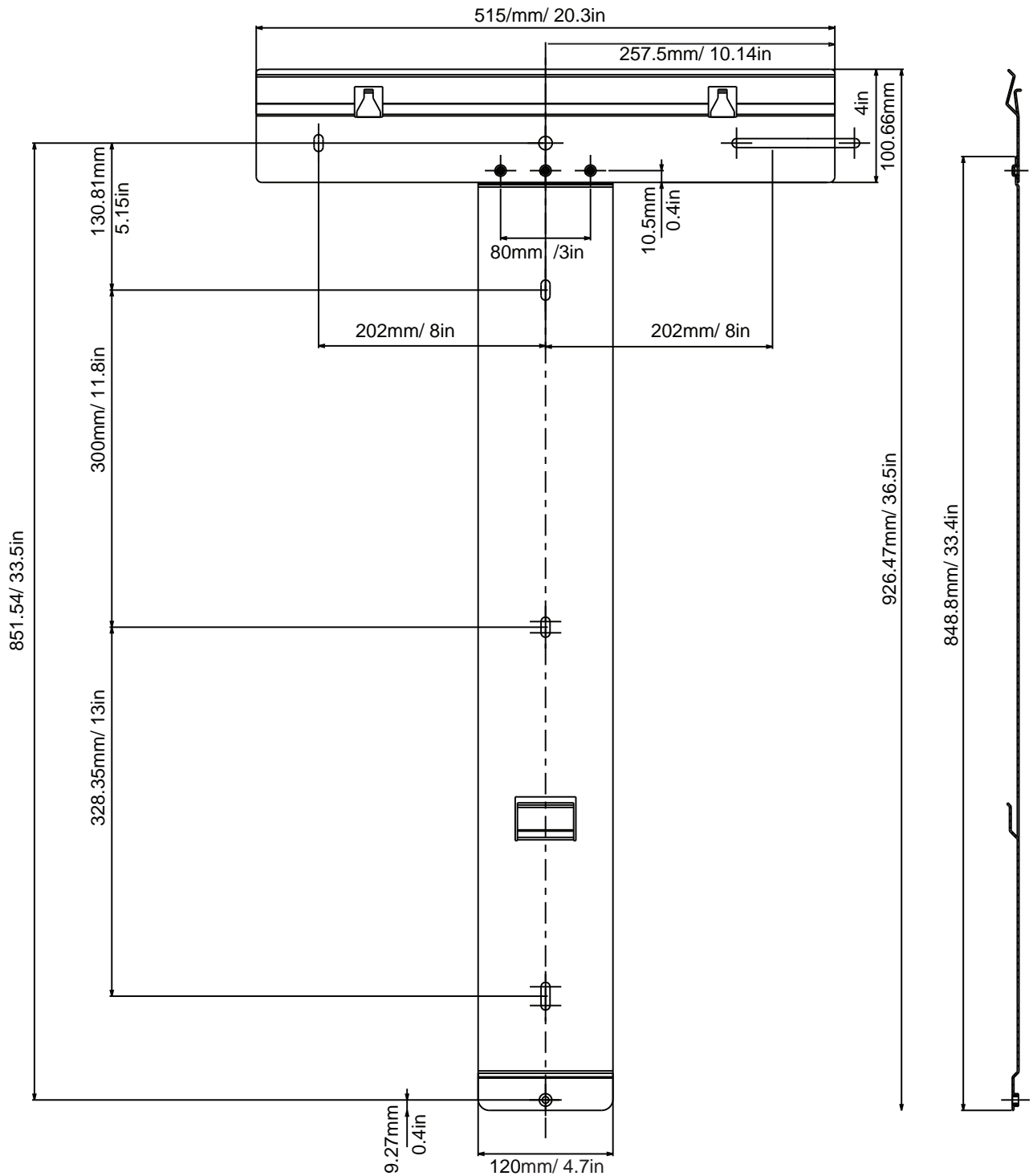

## Mounting PVI-10/12-I-OUTD-(S1, S2)

- Using the mounting bracket as a template, locate and mark the desired mounting location.
- Orient the bracket on the mounting surface so the **C** hooks face outward and upward.
- Using the hardware provided, level and mount the bracket to the surface using mounting holes **B** and **A** shown at right.
- Hang the inverter on the mounted bracket by lifting the unit over and above the mounting plate.
- Guide the mounting brackets **C** and **E** into the upper and lower hooks **D** and **F** on the inverter back shown below.
- Confirm the connecting points in the bracket and back of inverter engage properly.
- Secure the inverter bottom using the machine screw (6x20mm and washer 18mm diameter) provided through center hole **H** on the inverter back and engage in the PEM fastener at point **G**.

 *If the installation is done on a concrete wall, the wall plugs provided should be used and mounting holes in the wall should have a 0.4" diameter and 3" depth. If the wall is made of material other than concrete, stainless steel screws are recommended.*

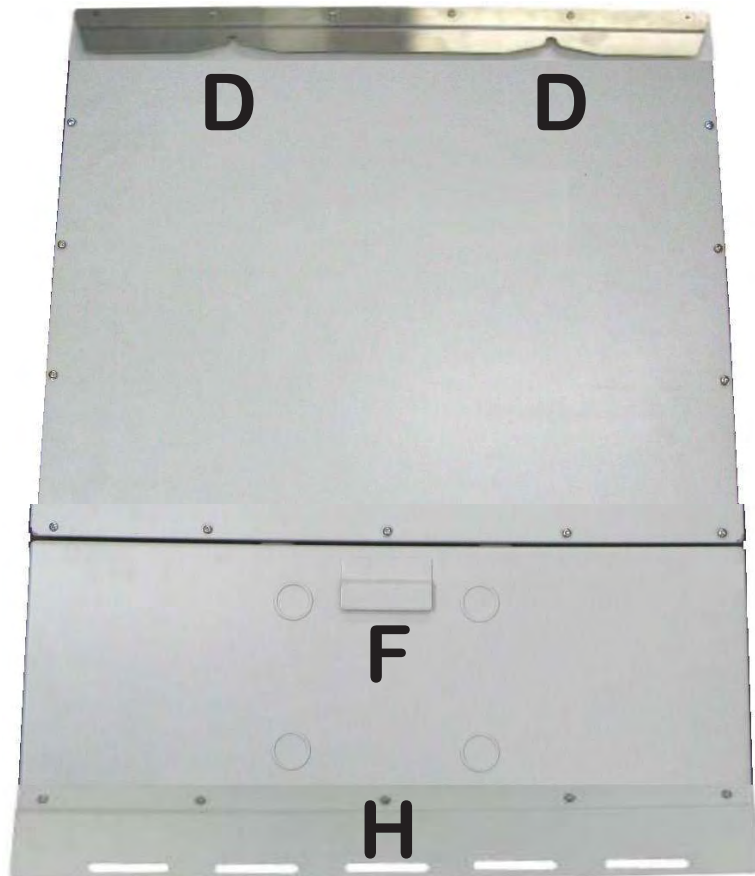
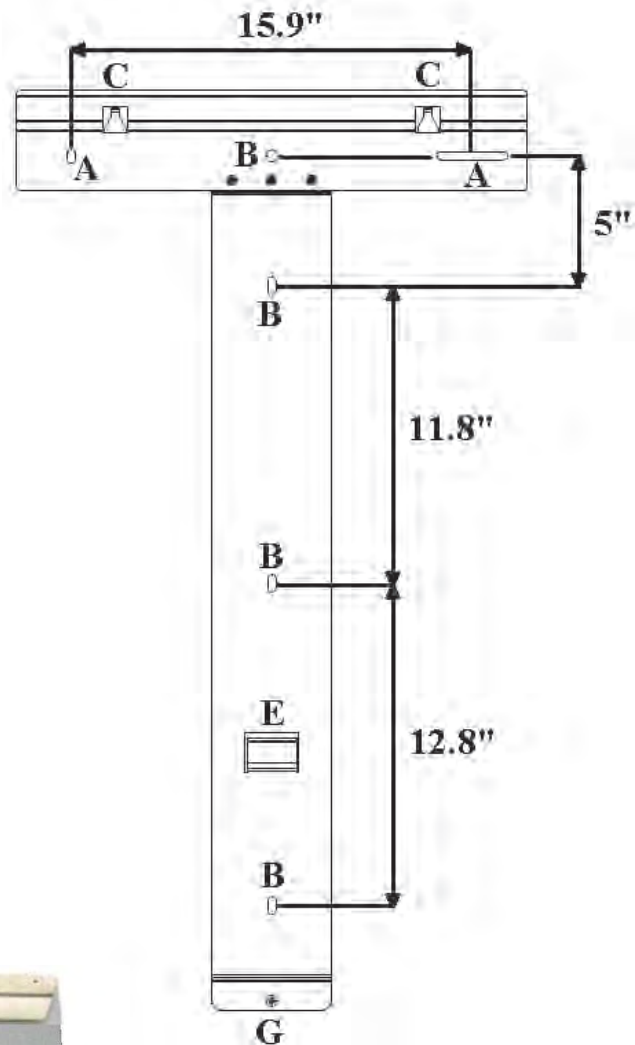

## Mounting PVI-10/12-I-OUTD no switchbox version

Mounting bracket for PVI-10/12-I-OUTD (no switchbox) is shown below; measurements are expressed in millimeters and inches.

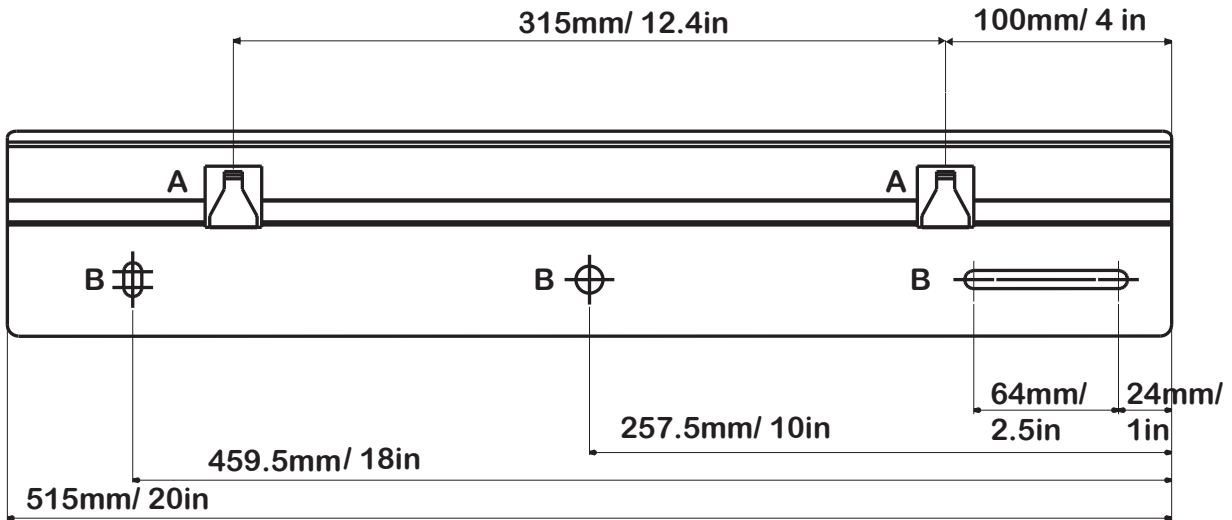

- Using the mounting bracket as a template, locate and mark the desired mounting location.
- Orient the bracket such that the **C** hooks face outward and upward.
- Using the hardware provided, level and mount bracket horizontally using mounting holes **A** and **B** shown at right.
- Hang the inverter on the mounted bracket, lifting the inverter over and above the mounting plate.
- Guide the mounting bracket **C** into hooks **D** on the inverter back shown below.
- Confirm the connecting points in the bracket and in the back of the inverter engage properly.

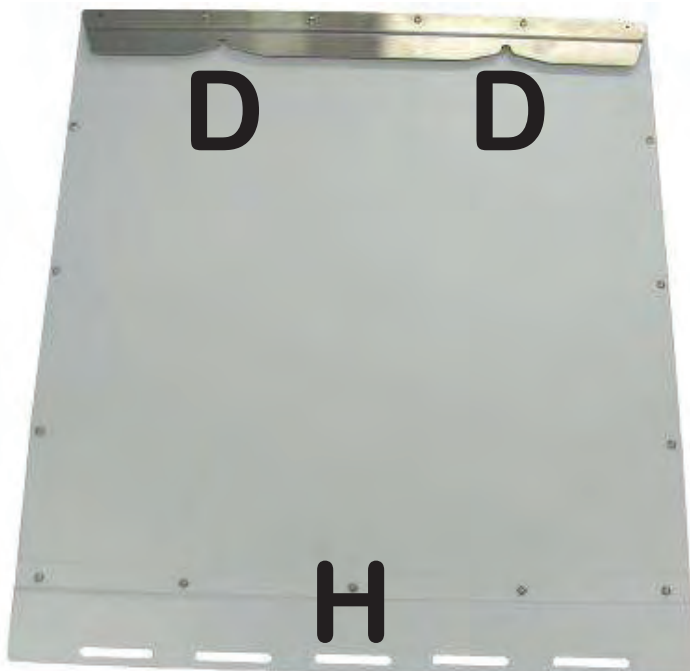
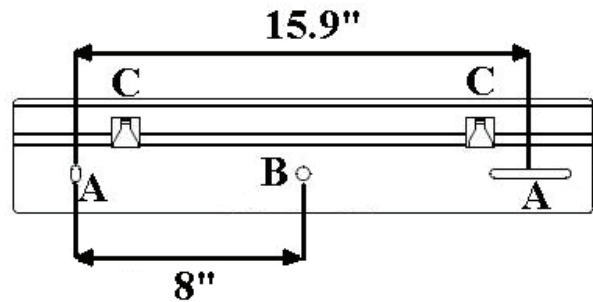

- Secure the inverter bottom to the mounting surface using the screw (6x20mm) and washer (18mm diameter) provided through center hole **H** on the inverter back.



*If the installation is done on a concrete wall, the wall plugs provided should be used and mounting holes in the wall should have a 0.4" diameter and 3" depth. If the wall is made of material other than concrete, stainless steel screws are recommended.*



### Preparing to connect the inverter



*It is the responsibility of the installer to provide external disconnect switches and overcurrent protection devices (OCPD) as required by NEC and other prevailing regulations.*

*Both the –S1 and –S2 switchbox contains a DC disconnect switch which disconnects the DC current from the photovoltaic panels when the switch is in OFF position but does not disconnect the AC connection to the grid. To disconnect the inverter from the AC grid, an AC switch must be disconnected.*

*The –S2 version is the only model that includes an integrated AC disconnect switch in the wiring box. AC output overcurrent protection is not provided for other models.*

- Ensure wire sizing procedures are completed per appropriate local codes and regulations.
- Field wiring terminals for inverters are rated at 90°C/194°F.
- Permanently mount the inverter in its operational location prior to beginning electrical connections.
- Use only qualified and properly trained personnel for the process of connecting the inverter to the electrical distribution grid, and only after receiving approval from the local authority having jurisdiction.
- Secure all signal wiring and conductors to prevent contact with either AC grid and/or DC array field wiring; maintain spacing between the AC grid wiring and DC array wiring; secure as necessary.
- Do not exceed the maximum array DC voltage input to each MPPT circuit of 520 Vdc under any condition.
- Do not exceed the maximum array DC current input of 24 Adc (10kW) or 25Adc (12kW) to each MPPT circuit.



## Wiring details

### Inverter connection board - all versions

M	grid selector/country code thumb wheel switches, set to [0/4]	T	INMODE S1 switch, MPPT input selector, select parallel or independent operation
N	DC array: MPPT 1 input, Note 1	U	alarm out terminals for external alarm, Note 2
O	DC array: MPPT2 input, Note 1	V	RS-485 bus connection via RJ485 connector, use with CAT5/6 cable
P	main PE ground terminal, Note 1	W	remote ON/OFF screw terminals
Q	3 ØAC grid output terminals, Note 1	X	RS-485 termination switch
R	3 ØAC grid neutral terminal for 4W grid connection, Note 1	Y	RS-485 bus connection via screw terminals, Note 2
S	3PHMOD switch 3ø mode selector, choose 3W or 4W grid connection	Z	connection wire to GFD fuseholder, (access fuseholder from switchbox)

**Note 1.** Terminals accept wire range of 12-4AWG (Refer to local code for appropriate wire size); torque to 13in-lb.

**Note 2.** Mating terminals in hardware kit. Terminals accept wire size range up to 16 AWG; torque to 8in-lb.

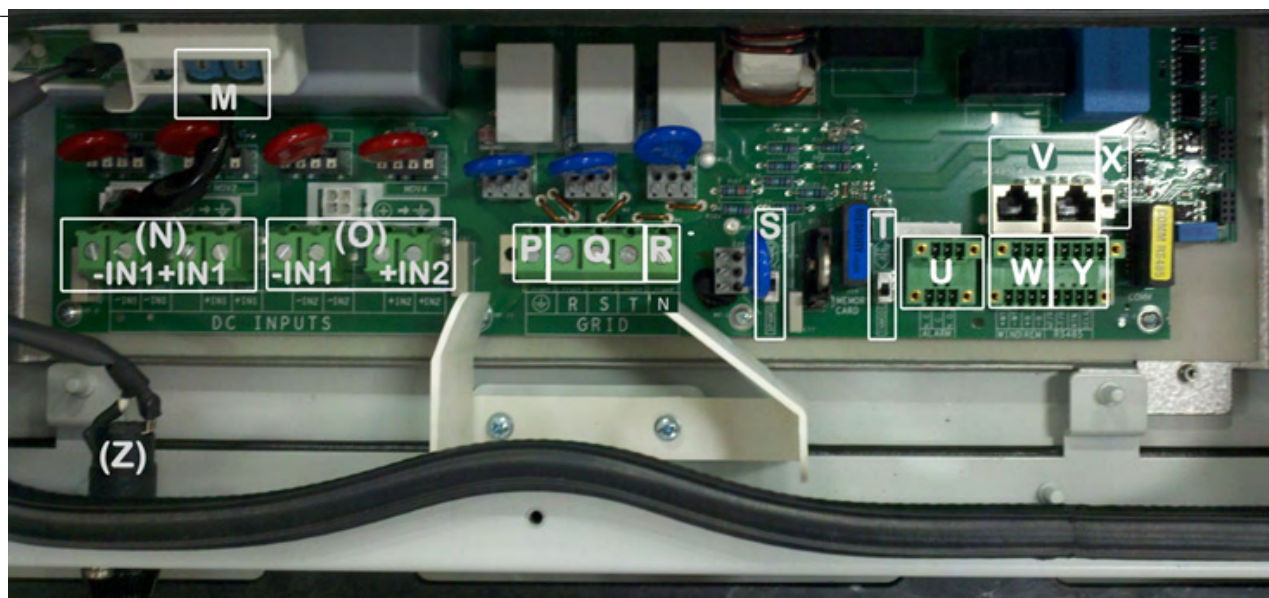



## Switchbox components

The switchbox components are described below and displayed in the following figures.

A	DC conduit entry KOs, ¾" and 1"	J	terminal block jumpers
B	AC conduit entry KOs, ¾" and 1"	K	array PE ground, Note 1
D	DC disconnect switch	+IN1	DC array MPPT 1, Note 2
E	AC disconnect switch	-IN1	DC array MPPT 1, Note 1
G	AC ground terminals, Note 3	+IN2	DC array MPPT 2, Note 2
H	grid output terminals (1,2,3,N), Note 3	-IN2	DC array MPPT 2, Note 1
I	conduit entry KOs with plastic plugs for signal cables	BT1-BT6	busbar terminals, Note 4
		F1-F6	fuse holders

Note 1: All array wiring terminal blocks are spring pressure type and can accommodate a wire size range of 20-6 AWG.

Note 2: Fuse holders F1 - F6 have screw terminals and torque depends on wire size. See label on fuse holders.

Note 3: All AC wiring terminals are spring pressure type and can accommodate wire size 12 - 4 AWG.

Note 4: Bus bar terminals BT1, BT3, BT4, and BT6 are used for various input wiring configurations.



*The DC disconnect switch electrically disconnects only the positive DC input leads, while the negative lead is not switched and grounded via the GFDI fuse.*

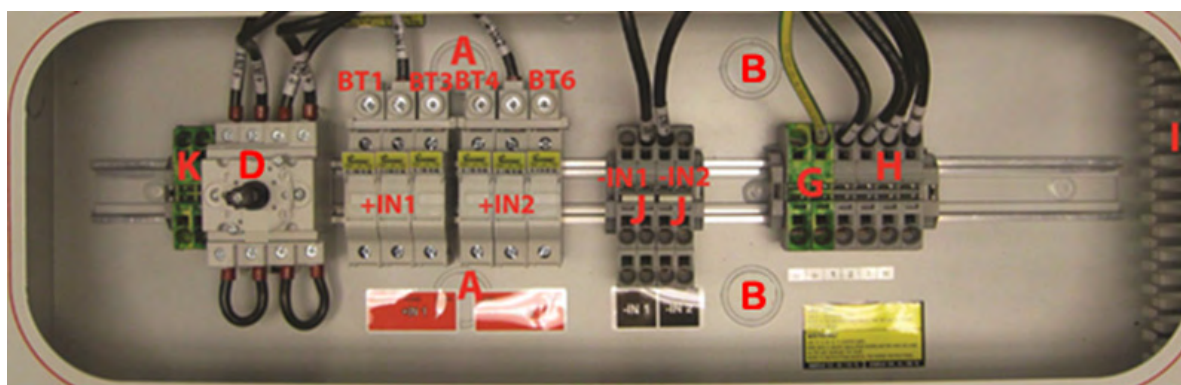

*PVI-10.0-I-OUTD-S1-US/CAN-XXX (with DC disconnect switch)*

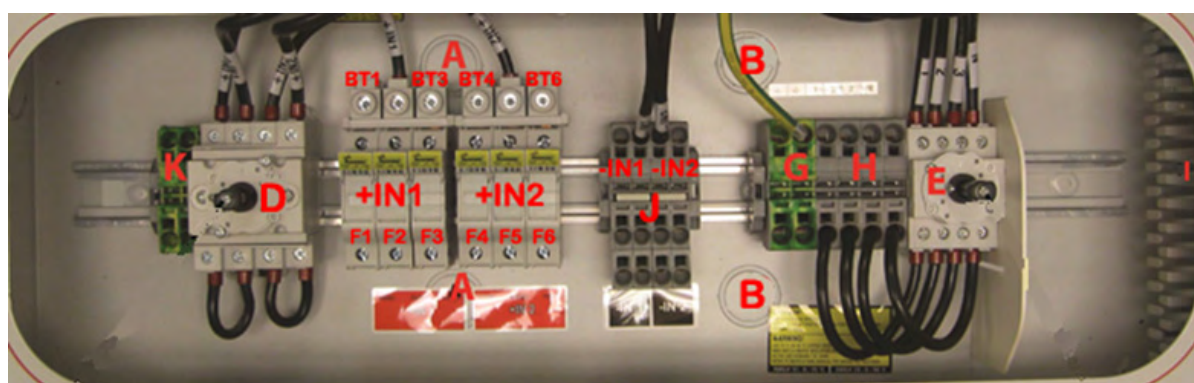

*PVI-10/12-I-OUTD-S2-US/CAN-XXX (with AC and DC disconnect switches)*

## Conduit and knockout details

The conduit entries and DC disconnect switch handle are described below. Make sure the appropriate conduit hub is employed for the use specified in order to maintain required spacing between wiring groups and ensure the integrity of the NEMA 4X environmental rating.

Not all details listed in the table below are included on each model.

A	DC conduit entry KOs, trade size 3/4", 1"
B	AC conduit entry KOs, trade size 3/4", 1"
C	Ground cable KO, trade size 1/2"
D	DC disconnect switch
E	AC disconnect switch
F	Signal cable conduit entries, trade size 3/4" - 1"
L	GFD fuse holder

### Conduit and knockout details PVI-10/12-I-OUTD

The PVI-10/12-I-OUTD does not have a switchbox; conduit entries are made from the bottom of the inverter chassis.

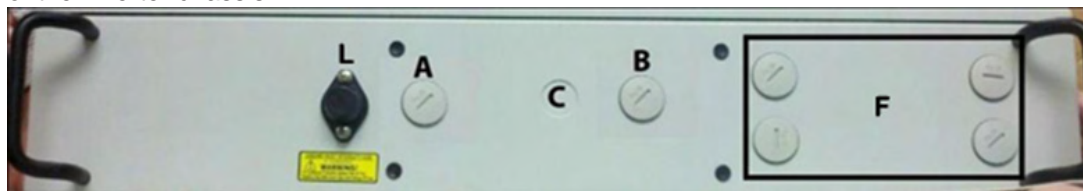

### Conduit and knockout details PVI-10/12-I-OUTD-S1

The PVI-10/12-I-OUTD-S1 is provisioned with a switchbox containing integrated DC switch.



## Conduit and knockout details PVI-10/12-I-OUTD-S2

The PVI-10/12-I-OUTD-S2 is provisioned with a switchbox containing integrated DC and AC disconnect switches.

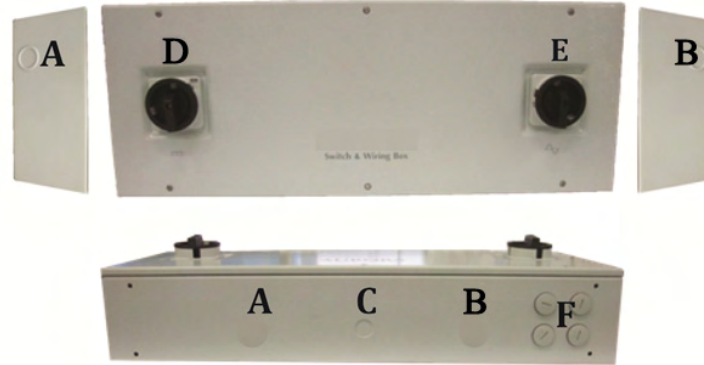

## Removing front covers

To access the wiring terminals in the inverter and switchbox the covers must be removed.

- To remove the front cover of the inverter compartment, loosen the six (6) captive screws using the Torx screwdriver provided.
- To remove the front cover of the wiring box, loosen the six (6) captive screws using the Torx screwdriver provided.
- When connection operations are complete, re-install the covers and tighten the cover screws with at least 1.5Nm (13.2 in-lbs.) torque to maintain proper waterproof sealing.

## Preliminary connection details

This section is dedicated to initial installation wiring of the inverter and assumes the unit has been physically mounted in its final location, but not yet wired.

Refer to Conduit and Knockout Details above and locate the designated entry locations for the conduits from the DC array and to the AC grid. Verify the appropriate knockouts have been employed for the use specified in order to maintain spacing between wiring groups.



The -S2 version is the only model that includes an integrated AC disconnect switch in the wiring box. For all other models an automatic over-current device (e.g., circuit breaker) must be used between the inverter and the distribution grid. Circuit breaker must be rated for bidirectional current flow. Rating of OCPD is dependent on specific grid connection.

## Typical connections PVI-10/12-I-OUTD

Typical system connections for this inverter are shown below. This version has no integrated disconnect switches or associated switchbox AND requires the installer to provide the following items:

1. **DC disconnect switch:** 2-pole, 600V rated. Current rating is based on the model chosen - refer to technical data in the Appendix. The switch must have two independent sections to accommodate the dual MPPT capability when used in independent mode. One 2-pole, 600V rated DC disconnect switch may be used if operating in parallel mode.
2. **AC disconnect switch:** 3-pole, with or without neutral block depending upon chosen grid connection (3W or 4W). Voltage and current rating depends on the grid connection voltage and output power of the inverter being installed.



Use care when accessing the DC array and AC grid wiring and associated terminals as this version has no integrated disconnect switches. Hazardous voltage is present unless the user-provided external disconnect switches are turned OFF and locked out. External disconnect switches for both the AC and DC connections are mandated by electrical codes.

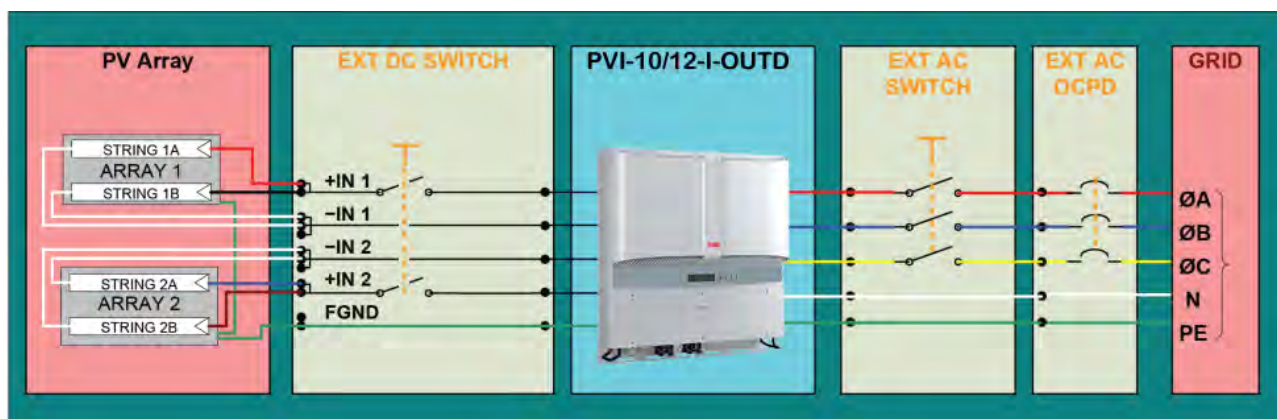



## Typical connections PVI-10/12-I-OUTD-S1

This version has an integrated DC disconnect switch and associated switchbox. It requires the installer to provide a (3)-pole AC disconnect switch. Voltage and current rating of this switch depends on the inverter model (grid voltage and output power) being installed. Typical system connection for this inverter is shown below.

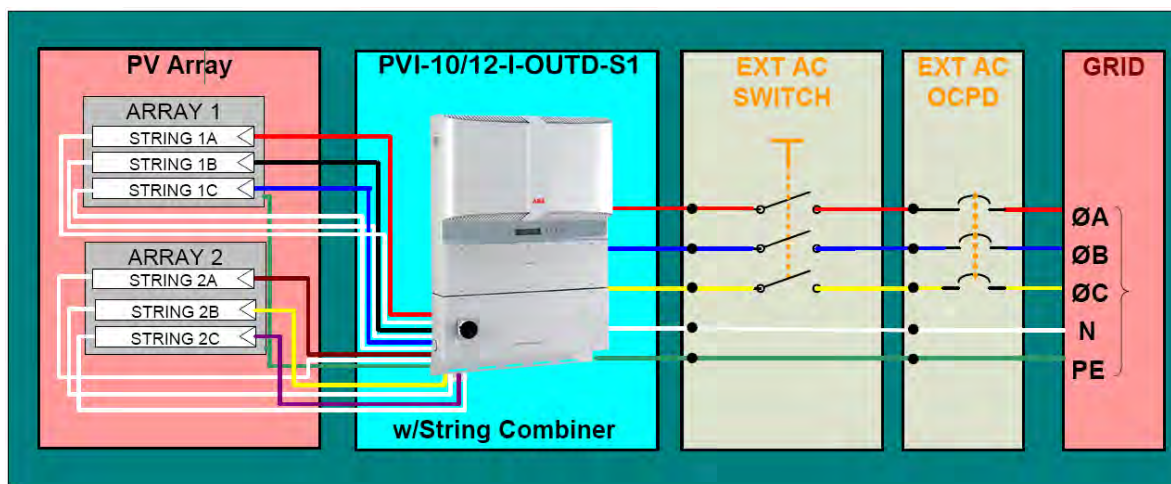

## Typical connections PVI-10/12-I-OUTD-S2

This version has an integrated DC and AC disconnect switches and associated switchbox. Typical system connection for this inverter is shown below.

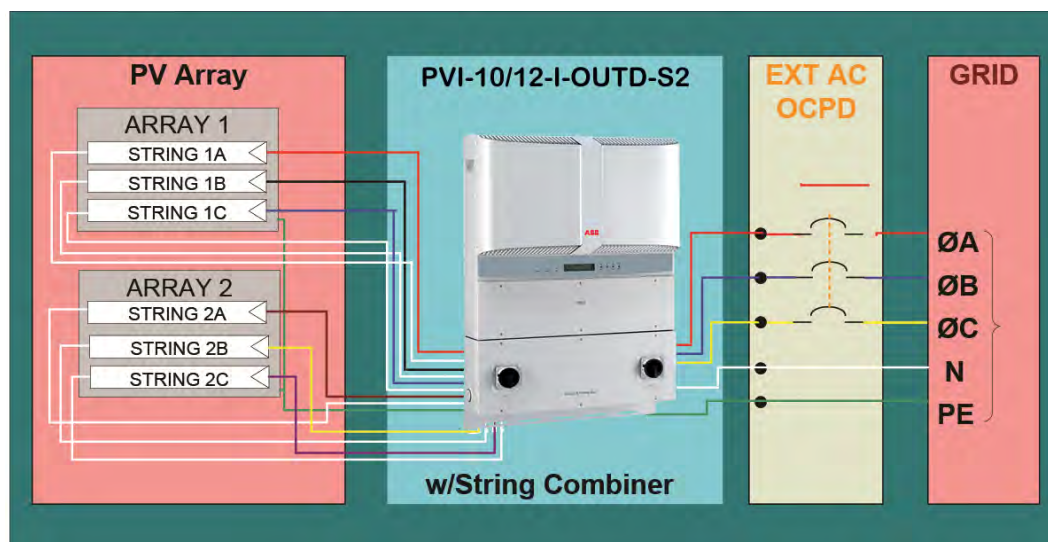

## Independent or parallel configuration of dual inputs

The inverter is configurable with an independent MPPT for each DC input channel or with the two input DC channels connected in parallel with one MPPT.

When operated in the dual input mode the inverter can optimize two independent arrays. The inverter can also be operated in a single MPPT mode from a single array by connecting the inputs in parallel using jumpers and proper setting of the INMODE switch (discussed below).

If the inverter is configured with two independent MPPTs, the maximum current for each channel must not exceed 24 Adc (10kW)/ 25Adc (12kW) and the power input for the single channel must not exceed 6.8 kW.

The inverter is configured in independent mode by default. The following section describes how to connect the inverter in parallel mode using jumper cables and the INMODE S1 switch.



### Inmode switch S1

INMODE switch S1 (item T on the inverter connection board) is used to select parallel or independent configuration of the inverter. The default position of the switch is in the IND position (DOWN).

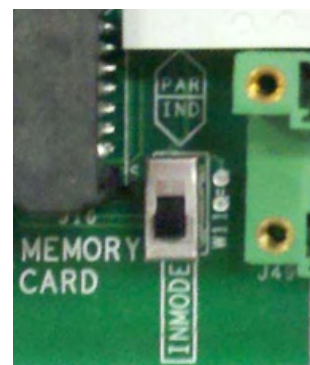

### Parallel mode PVI-10/12-I-OUTD

- Place INMODE S1 switch UP in the PAR position.
- On the inverter connection board, parallel the two MPPT inputs by means of terminal [-IN1 and -IN2] and [+IN1 and +IN2] using two 10 AWG jumper wires (1 black and 1 red cable) to connect the input as shown below.



## Parallel mode PVI-10.0/12.0-I-OUTD-(S1, S2)

- Place INMODE S1 switch UP in the PAR position.
- In the switchbox, connect bus bar terminals BT3 and BT4 together using a short 8AWG jumper
- In the switchbox, connect terminal blocks -IN1 and -IN2 return terminals together using 8AWG terminal block jumpers found in hardware bag.

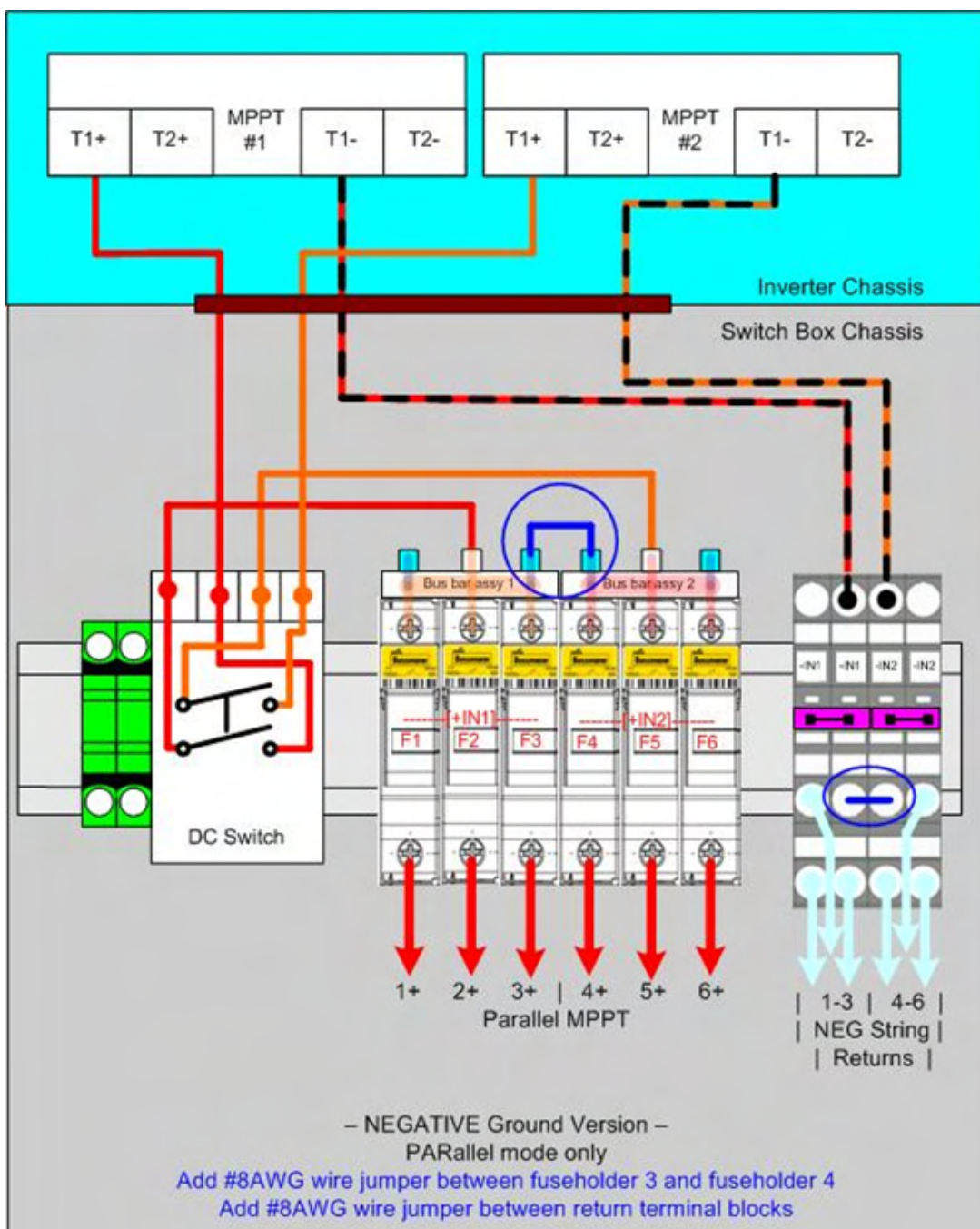

- The [-S1] and [-S2] models are provisioned with two 3-input fused combiner blocks consisting of three fuse holders bused to each MPPT input channel.
- The two combiners can be used independently for the IND mode, or they can be paralleled (in the switchbox) by use of jumpers for the PAR mode.

**External Combiner feed for Dual MPPT mode PVI-10/12-I-OUTD-(S1, S2)-US/CAN-XXX**

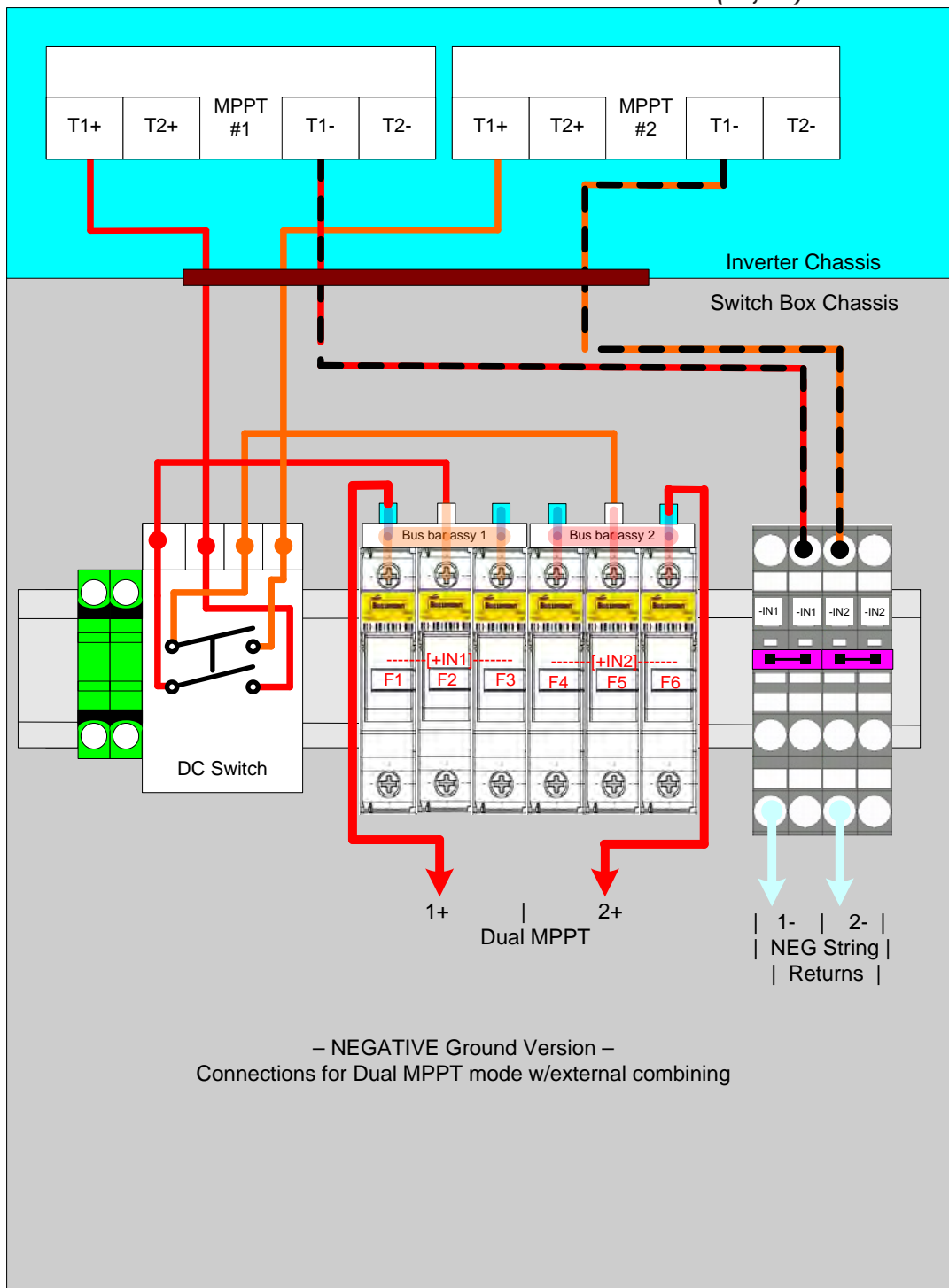



External Combiner feed for Single/Parallel MPPT mode PVI-10/12-I-OUTD-(S1, S2)-US/CAN-XXX-NG

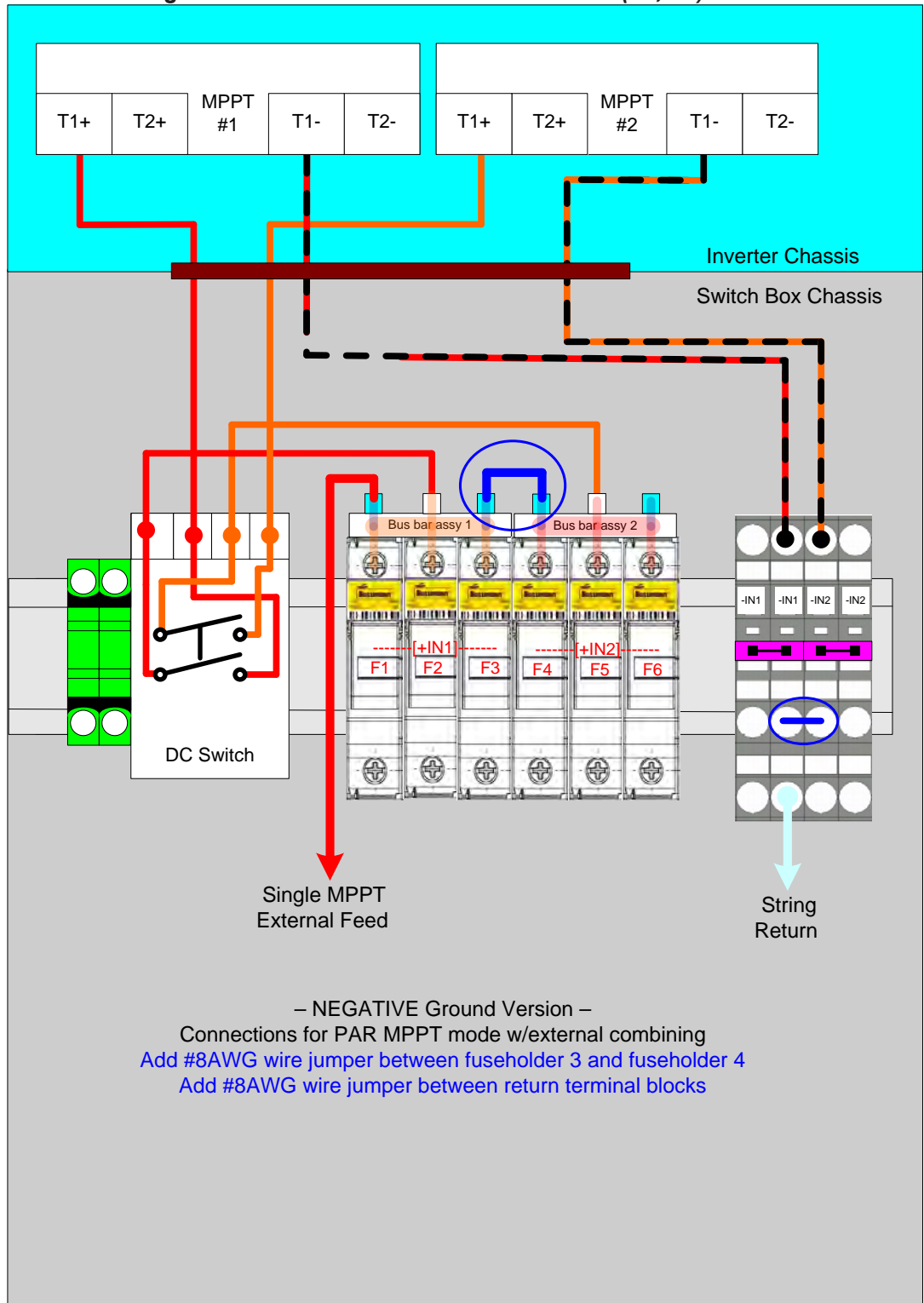

## DC array connections



Before attempting to connect the array wiring, be certain the array sizing has been completed to the specific plan associated with the system being installed. Use the string sizing tool at <http://stringsizer.com>.

To eliminate the potential for shock hazard during the connection procedure for the PV array wiring, either “open-circuit” all PV circuits prior to entry to the inverter and/or cover all panels with dark or opaque material in order to eliminate hazardous voltage at the terminals of the array wiring.

### DC array connections PVI-10/12-I-OUTD

- Locate the incoming DC array wiring at the inverter chassis and measure the voltage to confirm the array output is non-hazardous.
- Use 90°C rated wire and refer to local code for appropriate wire size.
- Acceptable wire size range is from 12 - 4 AWG.
- Tighten screw terminals to at least 13 in-lbs torque.

Connect the DC wiring to the MPPT1 and MPPT2 array terminals per the specific array design (see independent or parallel configuration above).

- If the array is wired for dual MPPT mode, run separate wires for POS and NEG for each array and ensure no jumpers are installed between the two inputs.
- If the array is designed for the parallel MPPT input mode, ensure the necessary jumpers are in place.
- Confirm the MPPT INMODE S1 switch is in the correct position to match the array design.

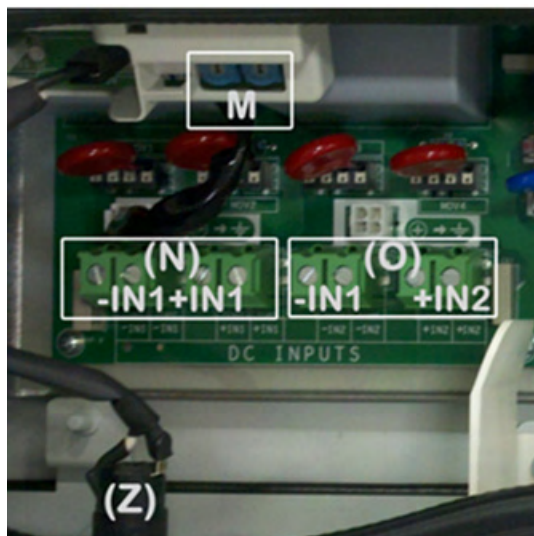

## DC array connections PVI-10/12-I-OUTD-(S1, S2)

- Locate the incoming DC array wiring at the switchbox chassis.
- Measure the voltage to ensure the array output is non-hazardous.
- Use 90°C rated wire and refer to local code for appropriate wire size.
- All array wiring terminal blocks are spring pressure type and can accommodate a wire size range of 20 - 6 AWG.

Connect the DC wiring to the MPPT1 and MPPT2 array terminals per the specific array design (independent or parallel configuration).

- If the array is wired for dual MPPT mode, run separate wires for POS and NEG for each array and ensure no jumpers are installed between the two inputs.
- If the array is designed for the parallel MPPT input mode, confirm the necessary jumpers are in place.
- **Confirm the MPPT INMODE S1 switch is in the correct position to match the array design.**



**When operating in PAR mode the input terminals in the switchbox must also be wired in parallel to ensure current through switch is equalized.**

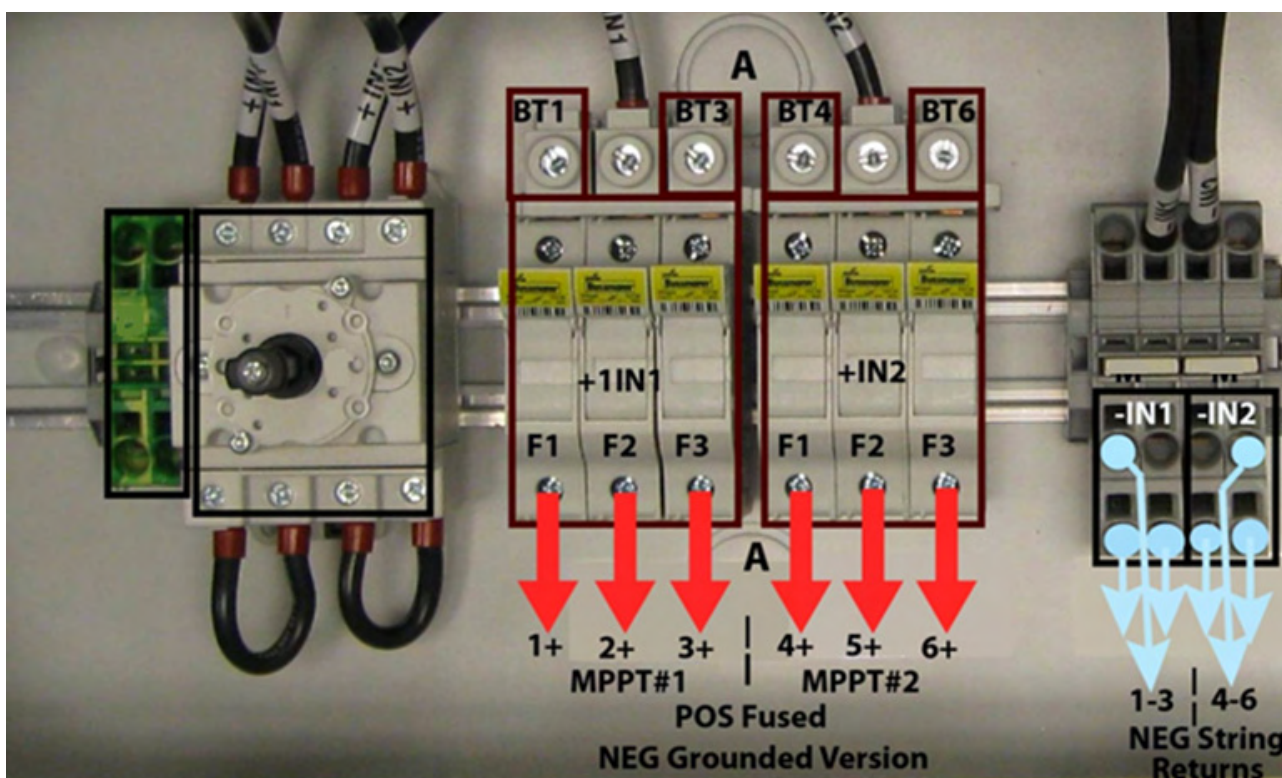

## AC grid connections

### Grid-type configuration 3PHMOD switch

The grid connection type (3W or 4W) is set using the 3PHMOD switch (item **S** on inverter connection board) and depends on the installation location and utility requirements. The default grid type is set to 4W-Y mode.

- The 4W-Y position (switch DOWN) is intended for connection of the inverter to a 4W grid including connection of a neutral conductor and is the factory default setting.
- The 3W- $\Delta$  position (switch UP) is intended for connection of the inverter to any 3W grid connection including a true 3W-delta grid or a 4W-Y grid without use of a neutral.
- The ability to connect 3W to a 4W-Y grid is typically governed by the local distribution company.
- The unit's voltage is pre-set at the factory and is reflected in the part number.
- All models require a 3-phase grid connection.



### AC grid connections PVI-10/12-I-OUTD

On the inverter connection board, connect the AC wiring to the AC grid terminals as shown below.

- Locate the AC grid wiring at the inverter.
- Measure the voltage to ensure all connections to the grid have been eliminated and no hazardous voltage is present.
- Use 90°C rated wire and refer to local code for appropriate wire size.
- Acceptable wire size range is from 12 - 4 AWG.
- Tighten screw terminals to at least 13 in-lbs torque.
- If the grid connection is to be 3W, the Neutral conductor does not need to be pulled or connected. Place the 3PHMOD switch UP in the 3W position.
- If the grid connection is to be 4W, the Neutral connection must be connected to the Neutral terminal. Place the 3PHMOD switch DOWN in the 4W position.

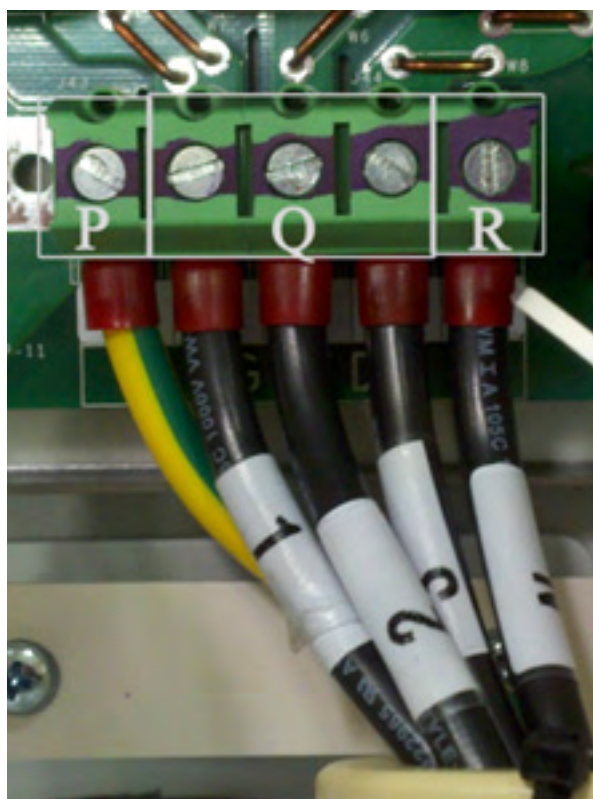



## AC grid connections PVI-10/12-I-OUTD-(S1, S2)

- Locate the AC grid wiring at the switchbox.
- Measure the voltage to ensure all connections to the grid have been eliminated and no hazardous voltage is present.
- Use 90°C rated wire and refer to local code for appropriate wire size.
- All grid wiring terminal blocks are spring pressure type and can accommodate a wire size range of 12 - 4 AWG.
- For a four wire WYE grid, connect Neutral, L1, L2, L3.
- For a Delta grid or three wire connection to a four wire grid, connect L1, L2, L3.

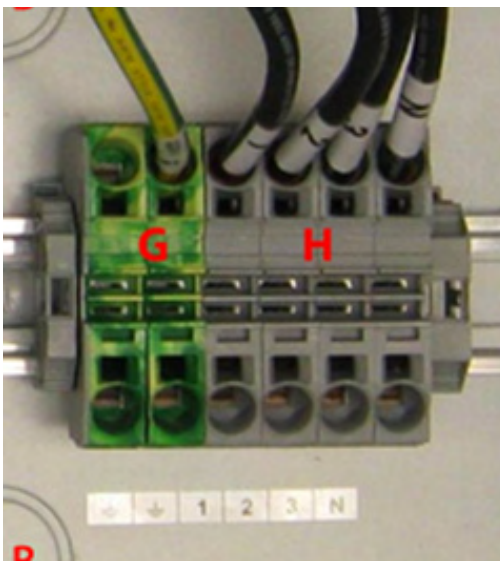

PVI-10.0-I-OUTD-S1



PVI-10.0-I-OUTD-S2

If the grid connection does not require a neutral connection (i.e., 3 $\emptyset$ /3W), the Neutral is not used. Ensure the 3PHMOD switch is placed in the 3W position.

If the grid connection requires a neutral connection (i.e., 3 $\emptyset$ /4W) the Neutral terminal must be connected to the grid neutral conductor. Ensure the 3PHMOD switch is placed in the 4W position.

## Setting the grid/country standard and language

- The inverter has a two-selector switch (labeled as item M on the inverter board) that enables installers to set the proper grid standard.
- The factory default setting is [0, 4].
- To access the selector switches remove the inverter front panel.
- Confirm the switches are set to positions [0, 4], change if necessary.
- Settings become fixed after 24 hours of operation (the inverter does not need to be connected to the grid, but only needs DC power to count operation time).
- During the first 24 hours of grid connection it is possible to modify the chosen standard if necessary.
- After 24 hours, the setting is finalized and cannot be changed without contacting customer service.
- Users can check the counter residual time via the LCD scrolling menu described in Operations, section 4.



**Before turning the rotary switches, make sure the inverter is switched off**

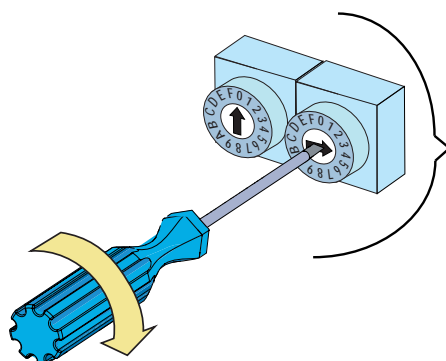

## Communication and signal connections

Wiring for the RS-485 communication system and hardwired control options must be routed into the main inverter chassis for termination. Whether these cables need to be protected by conduit depends on the applicable wiring code.

- If no conduit is used, the cables should be brought into the wiring box via a 1/2" box connector with rubber cable glands to maintain NEMA 4X rating.
- If conduit is used, run the appropriate raceway and terminate it to the wiring box chassis using a conduit connector that matches the raceway.
- The conduit must be terminated at one of the two 1/2" signal openings.

### **For switchbox versions S1 and S2**

- Route the cables into the switchbox through appropriate conduit.
- Use the plastic guide in the switchbox to route the cables in to the inverter chassis.

### **For the No Switchbox version**

- Route the cables directly into the inverter chassis through the appropriate conduit.

Monitoring and alarm connections are shown below.

## Serial communication connection (RS-485)

- The RS-485 communication line connects the inverter to the monitoring devices and may be “daisy-chained” (in-out) among multiple inverters.
- The RS-485 connecting cables can use both the terminal connections, as well as the RJ45 connectors, to connect to the dedicated port.
- If the terminal blocks are used, the signals RTN, +T/R and –T/R have to be cabled.
- If the RJ45 plugs are used, the pin-out is shown on the next page.
- Use a cable designed for use with RS-485 communications, which has a twisted pair for the +/-T/R signals and a third conductor used as a return (RTN).
- The figure below shows a cable with two twisted pairs where one pair is shorted together to create a RTN line.
- Another choice such as Belden 3106A, is a data cable wire with one twisted pair, one ground conductor, and a shield with drain wire (equivalent).

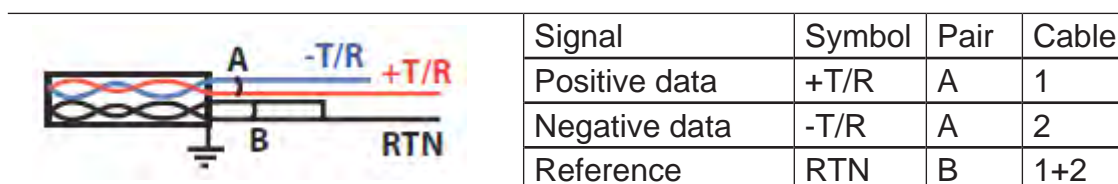

Continuity of the shield in the RS-485 cable is important for low noise on the line; particularly for large plants with multiple inverters. For best results the shield must be tied to ground at only one point on the line, typically at one end or the other.

The shield wiring must be continuous as it passes from one inverter to the next on a daisy chain, but must not be tied to ground at these junctions. The SCLD terminal can be used as a floating tie point for this purpose. It allows shields (drain wires) from incoming and outgoing daisy chain cables to be secured together but not grounded.

- If using standard multi-wire cable (such as Belden 3106A) locate the 8 pin mating connector, found in hardware bag, and connect the three RS485 leads
- Connect the three RS-485 leads (-RTN, +T/R, -T/R) to mating connector points corresponding to the terminal block.
- Attach the mating connector to terminal block at corresponding points.
- For systems with multiple inverters, two parallel terminal rows are on the terminal block and two mating connectors are included for this purpose.

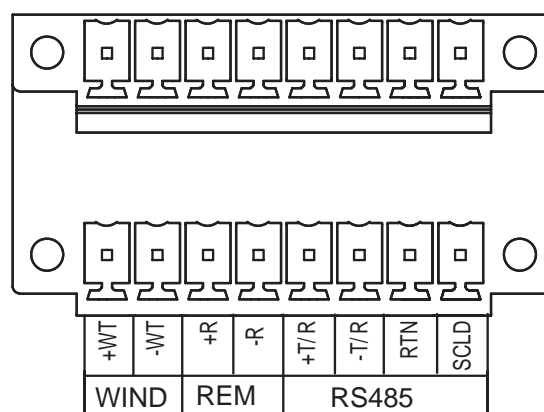

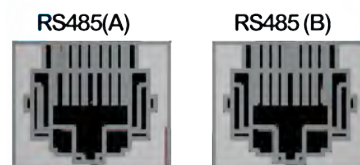

**The ±WT (WIND) terminals are not isolated and can have hazardous voltages present. These terminals must not be utilized for any purpose**

The two RJ45 connectors available for the RS-485 communication are equivalent to each other and can be used interchangeably for the input or output of the line when creating a daisy chain connection of the inverters.

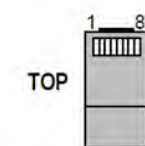

#### Pin-out of RJ34 connector plugs

	Pin #	Function
 TOP	1,2,6,8	Not Used
	3	+ Data Line (+TR)
 FRONT	4	Remote OFF (+R)
	5	- Data Line (-TR)
	7	Signal Return (RTN)

## Daisy chain units for connection to a monitoring system

- The RS-485 terminal block connectors or RJ45 connectors can be used to connect a single inverter or implement a multi-unit wiring configuration (daisy chain).
- The recommended length of total communication cable line for all inverters in the system is 3,300ft/1000 meters or less.
- Depending on the type of computer used, the cable line adaptor can be RS-485 to RS232 or RS-485 to USB.
- In order to ensure optimum communication on the RS-485 line, it is recommended to connect the RS-485 converter to a location between the first unit in the daisy chain or multi-unit system configuration and the computer; not in between two inverters in the series.
- Using the appropriate cable, daisy chain the inverter units RS-485 lines in a series.
- On the last inverter in a daisy chain, or on a single inverter, activate the termination resistance for the communication line by moving the S3 switch (labeled item X on the inverter board) down into the ON position.
- All other inverters in the daisy chain will have the S3 switch placed up in the OFF position.

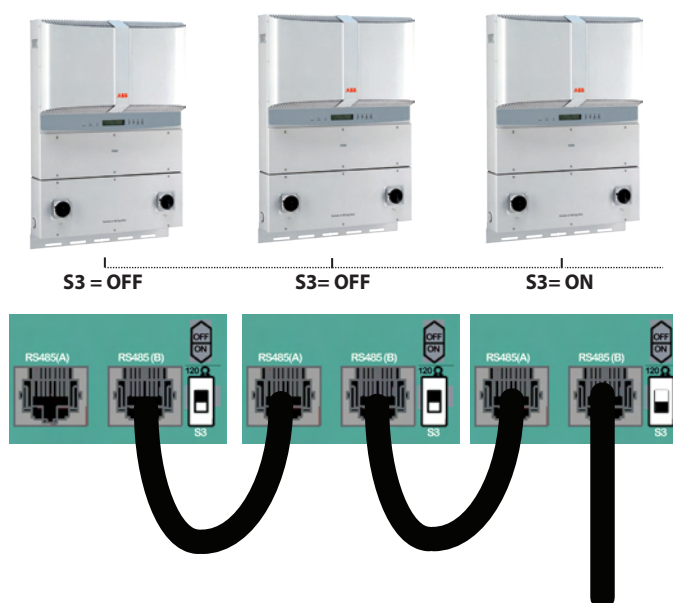



## Addressing each inverter

- When multiple inverters are connected on a single RS-485 bus, it is necessary to assign a different RS-485 address to each unit.
- The address on the inverter is set through the user interface on the display panel (see Operations, section 4).
- Address values are assigned manually using any value in the range 2 to 63.
- Set a different RS-485 address for each inverter of the chain.
- The default setting for the RS-485 address is 2, and termination switch S3 in the OFF position.
- No more than 63 inverters can be connected on a single RS-485 link.
- The number may be less depending on the data logger used.
- Do NOT to exceed a length of 3,300 ft/1000m for the RS-485 communication line.



## Monitoring system via serial (RS-485)

The RS-485 line can be connected to various monitoring devices that can be in local or remote mode:

- Local monitoring from PC with a PVI-USB-RS485\_232 adaptor and Aurora Communicator software.
- Local monitoring from a remote display such as the PVI-DESKTOP device with a PVI-USB-RS485\_232 adaptor.
- For local monitoring, a PVI-USB-RS485\_232 brand adaptor is recommended for connection between the first unit of the daisy-chain and the computer.
- Equivalent RS-485 to RS-232 adapters found on the market can also be used for the same purpose; however, they have not been specifically tested in order to guarantee correct operation of the connection. These devices may also require external termination impedance, whereas this is not necessary with the PVI-USB-RS485\_232.

## Configurable relay connection (Alarm)

- The inverter has a multi-function relay provisioned with a removable screw-terminal mating connector to simplify connections to the terminal block.
- The relay output can be configured to activate a visual and/or audible alarm or be utilized by another control such as a building control system.
- The signal logic can be controlled by the user by using either the normally open (N/O) contact – or the normally closed (N/C) contact.
- Connect alarm cable to the 3-pin mating connector and plug mating connector into corresponding positions on Alarm terminal labeled **U** on the inverter connection board.

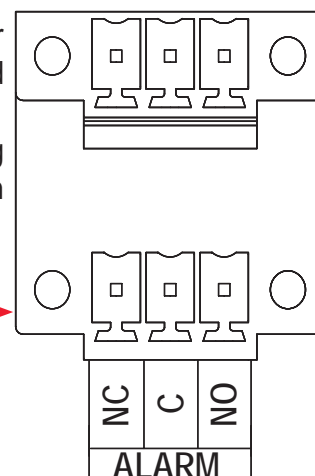

The relay can be used in four different operating modes which are set using the associated Settings menu of the inverter display. See Operations, section 4, for descriptions and instructions to program the connection.

The device to be connected to the relay can be of different types (light, sound, etc.) but must comply with the following requirements:

Alternating current	Max Voltage: 240 Vac	Max Current: 1 A
Direct current	Max Voltage: 30 Vdc	Max Current: 0.8 A

## Remote control connection

- The connection and disconnection of the inverter to and from the grid can be controlled remotely through an external control.
- The function must be enabled in the associated Settings menu; see Operations section 4.
- If the remote control function is disabled, the inverter automatically switches on and off in response to appropriate conditions.
- If the remote control function is enabled from the menu, the switching on of the inverter also depends on the state of the R\_ON/OFF terminal compared to the GND terminal present on the connector.

If the function is enabled as noted above :

- With the +R and -R terminals open (floating) the inverter operates normally
- With the +R and -R pins shorted together the inverter is disconnected from the grid and a “Remote Control OFF” message is shown on the display.

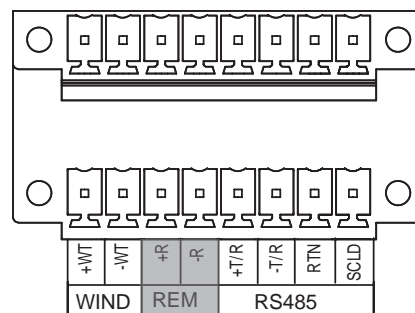

Since this is a low-level digital input, the wiring to the +R, -R terminals is typically small (18AWG to 24 AWG).

## Monitoring and data transmission



*One of the first rules for preventing damage to the equipment and injury to the operator is to have a thorough knowledge of the user interface operations.*

*ABB cannot be held responsible for damage to the equipment or the operator if caused by incompetence, insufficient qualifications or lack of training.*

### Types of data available

The inverter is able to provide information about its operation through the following:

- Warning lights (LEDs)
- LCD for displaying operating data
- Data transmission through a dedicated serial RS-485 line

The inverter provides two types of data:

#### Real-time operating data

Real-time operating data can be transmitted on request through the communication lines and are not recorded in the inverter.

The Communicator software (available on the product page on the website) can be used to transmit data to a PC.

#### Internally stored data

The inverter internally stores a set of data that is necessary for processing statistical data which includes an error log with time stamps.

## User interface

There are three indicators on the LED panel and four programming control buttons on the keypad, shown on the next page. The status of the LED indicators is described in the following tables. The buttons are used to review data on the display, and access the data logged internally on the inverter, using menus described in this section.

Data can also be collected by a PC or a data logger equipped with an RS-485 port. If an RS-485 line is used, it may be convenient to use the RS-485/RS232 Serial Interface Converter model number PVI-RS232485. An optional Easy Control data logger is also available.

LED	Description
Green POWER LED	Indicates that the inverter is working correctly. This LED flashes while the grid is being checked when the unit is commissioned. If a valid grid voltage is measured, the LED stays on continuously, provided there is sufficient wind energy to activate the unit. If not, the LED continues to flash until there is sufficient wind energy for activation. During this phase, the LCD shows the "Waiting for Sun" message.
Yellow ALARM LED	Indicates that the inverter has detected an anomaly; the type of problem is shown on the display.
Red GFI LED	The GFI (ground fault indicator) LED indicates that the inverter has detected a ground fault on the DC side of the PV array. When this fault is detected, the inverter immediately disconnects from the grid and the relevant error warning appears on the LCD.

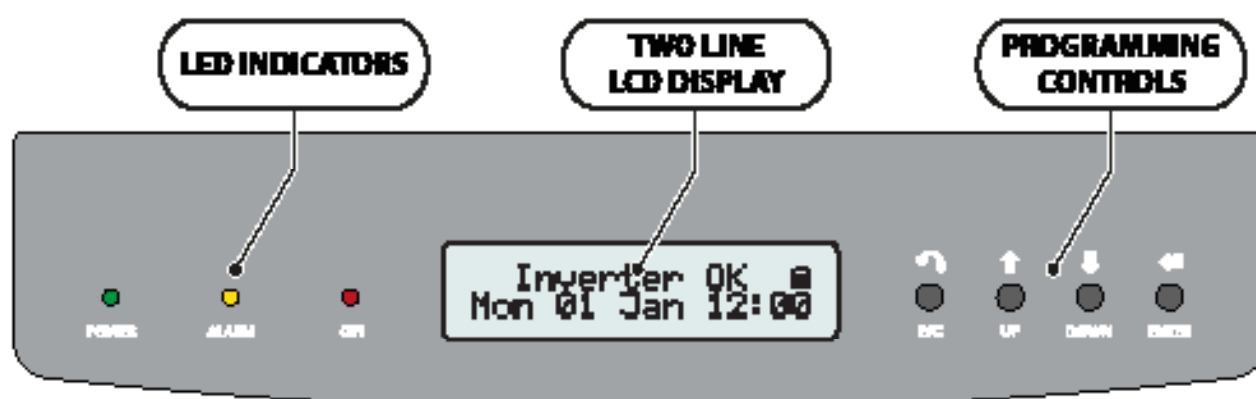

Programming controls	Description
ESC button	Use the ESC button to exit a mode or go back.
UP button	Use the UP button to read the data on the display by scrolling upwards, or to increase the set value during data entry.
DOWN button	Use the DOWN button to read the data on the display by scrolling downwards, or to decrease the set value during data entry.
ENTER button	Press ENTER to confirm the operation or to enter the set data item.

During operation, the display cycles through available data points, updating every five seconds. Screens may be scrolled manually by pressing the UP and DOWN programming control keys. Pressing the ESC key gives access to the three main menus: Statistics, Settings, and Information. To return to the preceding menu, press the ESC key.

























The three menus can be accessed with just the array connected. Some parameters (e.g., current, voltage, power, partial energy, lifetime energy etc.) are available only after grid connection.

Activation of cyclical scrolling will be indicated by two arrows in the top left corner of the two-line display. Scrolling can be blocked by pressing the ENTER key. A padlock symbol will appear.

## LED indicators

In their various combinations, the LEDs can indicate conditions that are different from the single one. The table below shows the possible combinations of activation of the LEDs in relation to the operating state of the inverter.

Warning and Error messages referenced below are described in Troubleshooting, section 5.

LED BEHAVIOR			
LED off	LED on	LED flashing	any condition
			
LEDs Status	Operational Status	Remarks	
1 green:  yellow:  red: 	Inverter is not operating	Input voltage less than 50Vdc at the input	
2 green:  yellow:  red: 	Inverter is initializing, loading settings and performing grid check	Transition status while operating conditions are checked	
3 green:  yellow:  red: 	Inverter is powering the grid	Normal operation	
4 green:  yellow:  red: 	Inverter is shut down because of a GFI fault	Ground fault has been detected	
5 green:  yellow:  red: 	Inverter detected a fault	The fault can be inside or outside the inverter. See the alarm code appearing on the LCD	
6 green:  yellow:  red: 	Installation phase: inverter is disconnected from grid	During installation it refers to setup of the address for RS-485 communication	
7 green:  yellow:  red: 	Inverter is disconnected from grid	Indicates a missing grid connection	



## Commissioning



**Do not place any items on the inverter during operation.**

**Do not touch the heat sink when the inverter is operating, as some parts may be hot and cause burns.**

### Start-up procedure:

- 1) Set the AC disconnect switch (external or part of switchbox depending on version) to the inverter to ON.
- 2) Set the inverter's DC disconnect switch (external or part of switchbox version) to ON.
- 3) **Once both switches are closed, the inverter starts the grid connection sequence.**
  - The check routine may take from 30 seconds up to several minutes, depending on grid condition.
  - The routine is indicated by the flashing green LED marked POWER.
  - Three screens are shown on the display during the check routine:
    - a) Measuring isolation resistance: "Measuring Riso..." , connection in progress with progress indication.
    - b) Grid voltage value and status compared to specified values (within/outside range).
    - c) Grid frequency value and status compared to specified values (within/outside range).
- 4) **When the connection sequence is completed,** the inverter starts operating.
  - Normal operation is indicated by a warning sound and the green LED staying permanently ON, (sunlight is sufficient to export power to the grid).
  - If the check routine gives a negative result, the inverter will repeat the procedure until all grid voltage and frequency parameters and grid configuration are found to be in the specified range.
  - During this process, the green LED will keep flashing.

## Connection of system to the grid

The two-line Liquid Crystal Display (LCD) is located on the front panel and shows:

- Inverter operating status and statistics;
- Service messages for operator;
- Error messages and fault indications.

During regular operation, the display will cycle through available data. The display changes to a different screen every 5 seconds or screens may be scrolled manually by pressing the UP and DOWN buttons located to the right of the display.

1) The following screen is displayed upon inverter start-up:

Initializing . . .  
Please wait

2) The following screens may appear while waiting for the connection to be established:

Missing Grid . . .

Waiting Sun . . .

- While the system checks for grid connection to be established (“Missing Grid”), the yellow LED next to the display turns on continuously, while the green LED is flashing.
- When waiting for the input voltage to exceed 50Vdc (“Waiting Wind”), the green LED turns on steady.
- When the “Missing Grid” and “Waiting Sun” conditions are verified, the inverter is connected.

3) Time (seconds) to complete output voltage and frequency check.  
It takes from 30 seconds to several minutes to complete the operation.

Next connections  
2 secs

4) Shows instant output voltage value and within/outside range status.

Vgrid            223.8V  
In range



5) Shows instant output frequency value and within/outside range status.

Fgrid            60.17Hz  
In range

6) If measured instant values of voltage (step 4) and frequency (step 5) are outside of the allowed range, the following screens are shown alternately

- Next connections (screen 3)
- Vgrid (screen 4)
- Fgrid (screen 5)

7) Instant value of isolation resistance

Meas. RISO . . .  
In range

### **Error messages**

After the connection is established, the inverter runs a test cycle. If wrong data are found, the cycle is interrupted and an error code is displayed. Error codes and their meaning are shown in section 5.

Once the error has been corrected, the inverter resets all functions in progress and re-starts the connection.

## First phase - electric parameter monitoring

If the parameters measured in start up are correct, the system will proceed to the next checks.

**1A)** inverter part number.

1A	Type OUTD PN -----
----	-----------------------

**2A)** inverter serial number and firmware revision level.

2A	SN ----- xxxxxx FW rel. C.0.1.1
----	------------------------------------

**3A) E-tod** : Daily energy output.

**\$-tod**: Daily energy savings. Value is expressed in the set currency.

3A	E-tod 0 Wh \$-tod 0.0 USA
----	------------------------------

**4A) E-tot** : Lifetime energy output since first installation .

**E-par** : Partial energy output during selected period.

4A	E-tot ----- E-par 0 KWh
----	----------------------------

**5A) P-out** : Measured instant output power.

The second line of the display shows the higher of two temperatures:

5A	P-out 0 W T-inv °C
----	-----------------------

- **T-inv**: inverter temperature.

- **T-boost**: heatsink temperature.

**6A) Ppk**: Maximum peak power achieved since partial counter was activated.

6A	Ppk W Ppk Day W
----	--------------------

**Ppk Day**: Maximum peak power achieved during the day. Counter will reset when unit is powered off.

**7A) Vgrid**: Measured instant grid voltage.

7A	Vgrid 197 Vgrid Avg 0
----	--------------------------

**Vgrid Avg**: Average grid voltage during the last 10 minutes of operation.

8A	Igrid 0.8 A Fgrid 60.18 Hz
----	-------------------------------

**8A) Igrid**: Measured instant grid current.

**Fgrid**: Measured instant grid frequency.

**9A) Vin**: input voltage value.

9A	Vin 0 V I in 0.0 A
----	-----------------------

**Iin1**: Instant input current value.

**10A) Pin**: Measured instant input power

10A	Pin 0 W
-----	---------

**11A) Riso**: Measured insulation resistance.

Unlike the parameters discussed above, this is not an instant value but a measurement taken one time during inverter start-up.

11A	Riso 0.0 Mohm Ileak 73 mA
-----	------------------------------

**12A)** When all items described above test OK, the inverter shows a corresponding message in the display top line along with date and time in the bottom line.

12A	Inverter OK Wed 17 May 11:23
-----	---------------------------------

Clock malfunctioning or other non function-related faults

(faults that do not affect the inverter's ability to generate energy) will be shown in the bottom line of the display in place of date and time.

The following error messages may be displayed instead of date and time:

- CLOCK FAIL - indicates clock malfunction, contact service.
- BATTERY LOW
- SET TIME - appears the first time the unit is powered up or after the battery has been replaced.
- FAN FAIL - contact service.
- MEMORY FAIL - data logging malfunction; contact service.



# Description of the menus

The three main menus enable monitoring of the inverter’s operations and are outlined below. To access the menus from the initial screen, press the ESC button. An arrow on the left side of the display highlights the current selection.

- Only two lines can be viewed on the display.
- Use the UP and DOWN control keys to scroll through all selections.
- Press ENTER to open the submenu corresponding to the arrow.
- Press ENTER to make a selection, ESC to go back.

The Statistics menu is a view only display of internally logged inverter data. The Settings menu allows access to configuration and modification of the basic inverter settings. The Information menu is used to display inverter data and change the country standard. Following is an outline and description of each menu.

## Statistics menu



- Press ESC to open the display menus.
- Press ENTER to select the STATISTICS menu and access the submenus outlined below.

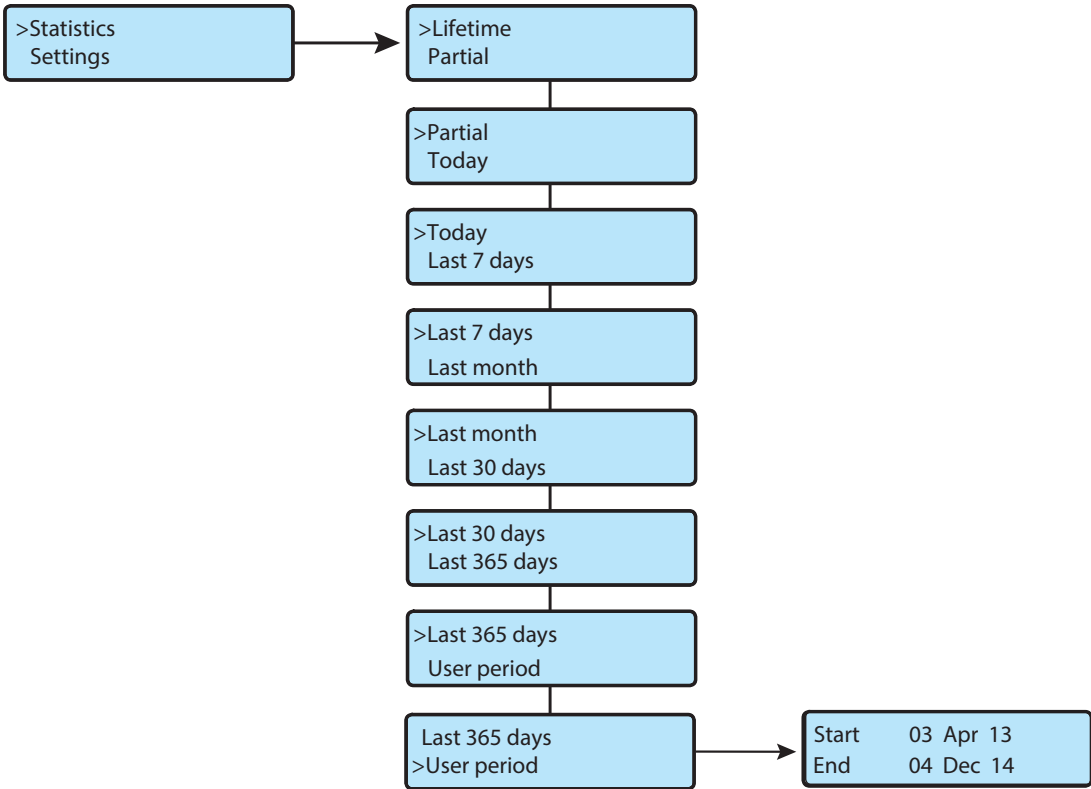

**Lifetime**

- Time: Lifetime operation time.
- E-tot: Total energy produced.
- Val. : Economic gain.
- CO2: CO2 saving compared to fossil fuels.

**Partial**

- Time: Total operation time since the counter was last reset. \*
- E-par: Total energy produced since the counter was last reset. \*
- PPeak: Maximum peak power measured since the counter was activated.
- Val. : Economic gain since the counter was last reset.\*
- CO2: CO2 saving compared to fossil fuels since counter was last reset. \*

\* To reset all counters in this submenu, press and hold the ENTER key until a warning sound is repeated 3 times.

**Today**

- E-tod: Total energy produced during the day.
- Ppeak: Peak power value achieved during the day.
- Val. : Economic gain during the day.
- CO2: CO2 saving for the day compared to fossil fuels.

**Last 7 Days**

- E-7d: Total energy output over the last 7 days.
- Val. : Economic gain over the last 7 days.
- CO2: CO2 saving over the last 7 days compared to fossil fuels.

**Last Month**

- E-mon: Total energy output during the month.
- Val.: Money earned during the month.
- CO2: CO2 saving compared to fossil fuels during the month.

**Last 30 Days**

- E-30d: Total energy output over the last 30 days.
- Val. : Economic gain over the last 30 days.
- CO2: CO2 saving over the last 30 days compared to fossil fuels.

**Last 365 Days**

- E-365: Total energy output over the last 365 days.
- Val. : Economic gain over the last 365 days.
- CO2: CO2 saving over the last 365 days compared to fossil fuels.

**User Period**

To create a user defined period of time, press ENTER from the *User period* screen to access the submenu below.

Use the display keys to set the start and end date of the period as follows:

- Use ENTER to move from one field to the next (from left to right).
- Use ESC to go back to the previous field (from right to left).
- Press ESC repeatedly to go back to the previous menus.
- To set the day:
  - Press DOWN to scroll numbers backwards (from 31 to 1).
  - Press UP to scroll numbers forwards (from 1 to 31).
- To set the month:
  - Press DOWN to scroll months from December to January.
  - Press UP to scroll months from January to December.

If the dates entered are inconsistent, the display alerts the user to the problem.



# Settings menu

- Press ESC to open the main menus.
- Scroll DOWN to *Settings* and press ENTER.
- The password screen is populated in the display.
- The default password is 0000; pressing ENTER four times loads four zeroes into the display and opens the submenus outlined below.

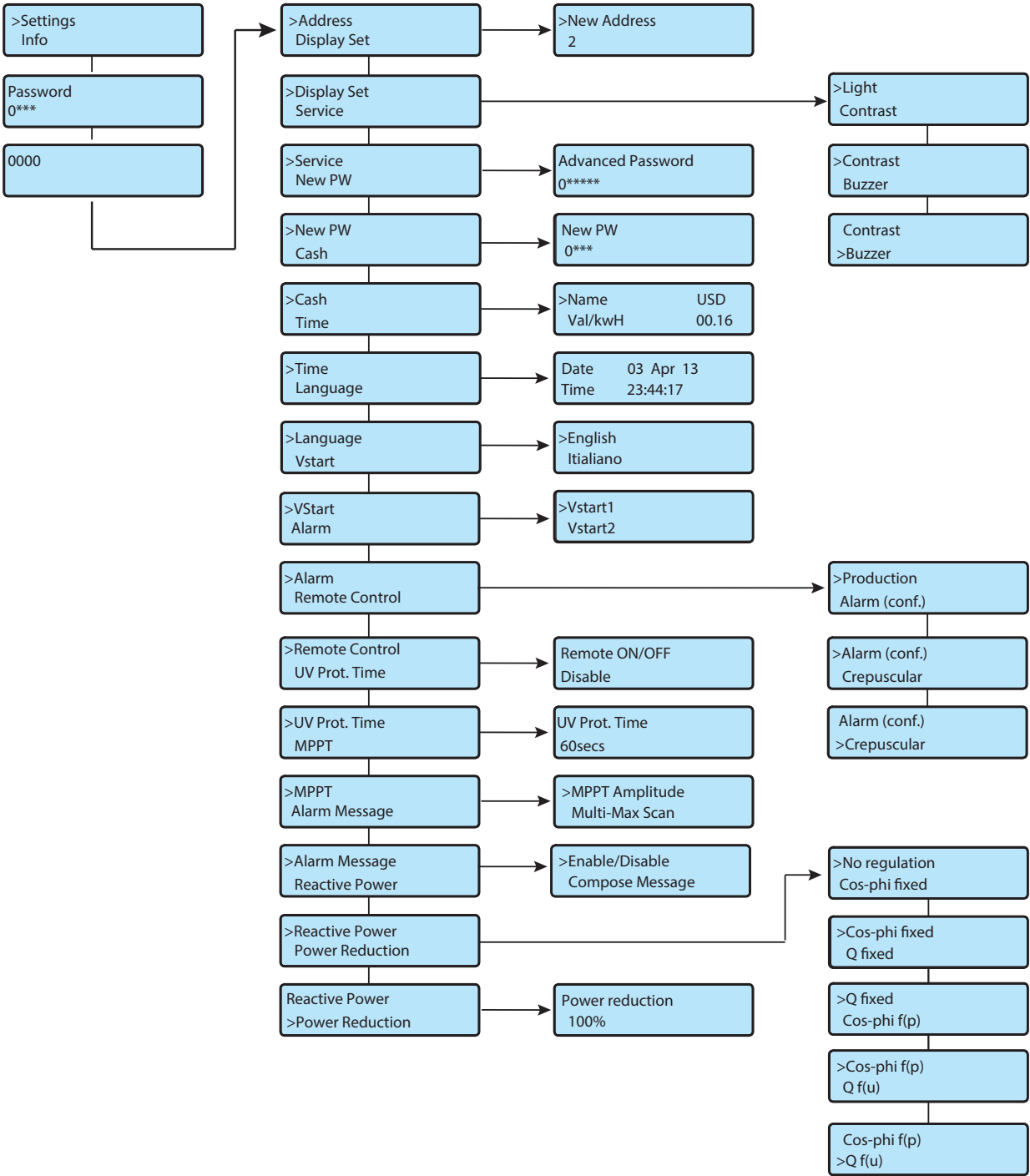

**Address**

Address enables the bus addresses (for the inverter connected to the RS-485 communication bus) to be set to an appropriate value.

- Address values are assigned using any value in the range 2 to 64.
- Press the UP and DOWN keys to scroll through numbers.
- Press ENTER to make a selection.

NOTE: If wiring multiple units using a daisy chain configuration, do not select AUTO configuration.

**Display Set**

Selecting this function displays the submenu enabling the user to set display feature parameters:

- 1) **Light** - select this menu choice to display light settings:
  - Select **MODE** to set the display backlighting.
    - ON: Light always ON.
    - OFF: Light always OFF.
    - AUTO: Light turns ON every time a key is pressed and stays on for 30 seconds before fading OFF.
  - Select **INTENSITY** and press ENTER to adjust the backlighting intensity from 1 to 9.
- 2) **Contrast**: Used to adjust display lighting contrast.
  - Available display light tones from 0 to 9.
  - Press UP and DOWN keys to scroll the numbers and then press ENTER to confirm the selection.
- 3) **Buzzer**: Set key tone setting, choices are:
  - ON: The key tone is ON.
  - OFF: The key tone is OFF.

**Service**

The *Service* menu can be used to adjust the voltage and frequency trip limit and trip time parameters according to the grid requirements of the installation locale. This inverter has been factory programmed to automatically disconnect from the utility distribution system in compliance with UL 1741 and IEEE 1547 specifications. Default voltage and frequency trip limit and trip time settings to comply with these standards are shown in the table below.

*ABB cannot be held responsible for any negative effects resulting from modifications of inverter set points.*

*The set points in the table below should only be changed with the written permission of the local utility.*

*Changes to the voltage and frequency trip limit and trip time parameters MUST be done by a qualified contractor or authorized personnel. Improper values entered could cause bodily harm and cause the inverter to shut down.*



This is a controlled access area of the operating system; contact customer service at 877-261-1374 to request an advanced password to access the submenus. The following table lists the default and adjustable parameters available in the *Service* submenu. Using the UP and DOWN keys on the inverter display panel, scroll to select the values for modification.

Parameter	Definition	Default Value	Adjustable Ranges
SET U>>	Indicates the value of the absolute over voltage set point beyond which the inverter disconnects from the grid. [115% of Nominal line to neutral Voltage]	319 V	Fixed
SET U<<	Indicates the value of the absolute under voltage set point below which the inverter disconnects from the grid [50% of Nominal line to neutral Voltage]	139 V	Fixed
SET F>>	Indicates the value of the absolute over frequency set point beyond which the inverter disconnects from the grid	63 Hz	Fixed
SET F<<	Indicates the value of the absolute under frequency set point below which the inverter disconnects from the grid	57 Hz	Fixed
SET U>	Indicates the value of the intermediate over voltage set point beyond which the inverter disconnects from the grid [110% of Nominal line to neutral Voltage]	305 V	305 V to 319 V
SET U>(10 min)	Inverter disconnects from the grid after 10 minutes in case the average grid voltage overcomes the threshold value(305V)	305 V	305 V to 319 V
SET U<	Indicates the value of the intermediate under voltage set point below which the inverter disconnects from the grid [88% of Nominal line to neutral Voltage]	244 V	139 V to 244 V
SET F>	Indicates the value of the intermediate over frequency set point beyond which the inverter disconnects from the grid	60.5 Hz	60.2 Hz to 63.0 Hz
SET F<	Indicates the value of the intermediate under frequency set point below which the inverter disconnects from the grid	59.3 Hz	59.8 Hz to 57 Hz
SET U Conn>	Indicates the value of the intermediate over voltage (line to neutral) set point to allow the inverter to connect to the grid for the first time.	305 V	305 V to 319 V
SET U conn<	Indicates the value of the intermediate under voltage (line to neutral) set point to allow the inverter to connect to the grid for the first time.	244 V	139 V to 244 V
SET F conn>	Indicates the value of the intermediate over frequency set point to allow the inverter to connect to the grid for the first time.	60.5 Hz	60.2 Hz to 63.0 Hz
SET F conn<	Indicates the value of the intermediate under frequency set point to allow the inverter to connect to the grid for the first time.	59.3 Hz	59.8 Hz to 57 Hz
SET TIME U>>	Indicates the value of the countdown timer associated with the Absolute Over Voltage setpoint U>>	0.16 sec	Fixed
SET TIME U<<	Indicates the value of the countdown timer associated with the Absolute Under Voltage setpoint U<<	0.16 sec	Fixed
SET TIME F>>	Indicates the value of the countdown timer associated with the Absolute Over Frequency setpoint F>>	0.16 sec	Fixed



Parameter	Definition	Default Value	Adjustable Ranges
SET TIME F<<	Indicates the value of the countdown timer associated with the Absolute Under Frequency setpoint F<<	0.16 sec	Fixed
SET TIME U>	Indicates the value of the countdown timer associated with the Intermediate Over Voltage setpoint U>	1 sec	0.16 sec to 5 sec
SET TIME U<	Indicates the value of the countdown timer associated with the Intermediate Under Voltage setpoint U<	2 sec	0.16 sec to 5 sec
SET TIME F>	Indicates the value of the countdown timer associated with the Intermediate Over Frequency setpoint F>	0.16 sec	0.16 sec to 300 sec
SET TIME F<	Indicates the value of the countdown timer associated with the Intermediate Under Frequency setpoint F<	0.16 sec	0.16 sec to 300 sec
SET TIME Conn 1	Indicates the time the inverter takes to connect to the grid for the first time (not after grid fault).	30 sec	1 sec to 3600 sec
SET TIME Conn 2	Indicates the time the inverter takes to connect to the grid after a grid fault.	300 sec	1 sec to 3600 sec
DISABLE U>>	Provides ability to enable/disable the Absolute Over Voltage Set point U>>	Enable	Disable or Enable
DISABLE U<<	Provides ability to enable/disable the Absolute Under Voltage Set point U<<	Enable	Disable or Enable
DISABLE F>>	Provides ability to enable/disable the Absolute Over Frequency Set point F>>	Enable	Disable or Enable
DISABLE F<<	Provides ability to enable/disable the Absolute Under Frequency Set point F<<	Enable	Disable or Enable
DISABLE U>	Provides ability to enable/disable the Intermediate Over Voltage Set point U>	Enable	Disable or Enable
DISABLE U> (10 min)	Provides ability to enable/disable the parameter "SET U>(10 min)"	Disable	Disable or Enable
Disable U<	Provides ability to enable/disable the Intermediate Under Voltage Set point U<	Enable	Disable or Enable
Disable F>	Provides ability to enable/disable the Intermediate Over Frequency Set point F>	Enable	Disable or Enable
Disable F<	Provides ability to enable/disable the Intermediate Under Frequency Set point F<	Enable	Disable or Enable
U>(10 min) Der.	Provides ability to limit the power for 10 minutes due to the high average voltage value set by the parameter "SET U>(10 min)"	Disable	Disable or Enable
Slow Ramp	Provides ability to slowly ramp the Output Power at connection( Soft start)	Disable	Disable or Enable
OF Derating	Provides ability to limit the Output Power due to the high grid frequency	Disable	Disable or Enable
Reset Country S	Provides ability to reset the country code	Not Applicable	Not Applicable

**New Password**

Default password (0000) can be changed to a 4-digit personal code.



*Be sure to memorize the new password; if it is misplaced it will not be possible to access the inverter and there is no RESET function available!*

To set a personal code, use the display keys as follows:

- Use ENTER to move from one digit to the next (from left to right).
- Use ESC to go back to the previous digit (from right to left).
- Press ESC repeatedly to go back to the previous menus.
- Press DOWN to scroll numbers backwards (from 9 to 0).
- Press UP to scroll numbers forwards (from 0 to 9).

**Cash**

Selecting this function enables the user to set the measurement units for earnings based on energy output.

- Name - set desired currency, using the UP or DOWN key; default currency is US dollar.
- Val/KWh: This indicates the cost of 1 kWh expressed in the currency set. The default setting is USD 0.16.

**Time**

Selecting this function allows adjustment of the system time and date settings.

**Language**

Selecting this function allows setting of the language desired for system prompts; default is English.

**Vstart**

Used to set the start-up voltage (separately for both channels if they are configured in independent mode).

Change the activation voltage only if necessary. A configuration program that can help to correctly size the photovoltaic system is available at <http://stringsizer.com>.

**Alarm**

Selecting this function accesses the inverter's alarm function, which is used for external controls or, for example, to activate a visual and/or audible alarm. The function controls a set of dry relay contacts, which can be wired by the user as either normally open (N.O.) or normally closed (N.C.); see Wiring, part 3, for connection instructions.

The operational modes are described below. Select the desired mode using the UP/DOWN arrow keys and press ENTER to open the relevant submenus.

- PRODUCTION: the relay switches when the inverter connects to the grid.
- ALARM (configurable): the relay switches if there are alarms (code E) or warnings (code W) chosen by the user from a list.
- CREPUSCULAR: the relay switches only when the input voltage exceeds the input voltage set for connection to the grid.

**Remote Control**

Selecting this function accesses the remote ON/OFF function used to disable the inverter operation by an external switch or an external controller. Hardware access to the ON/OFF function is via terminals +R and -R, shown in Wiring, part 3. With the function enabled, the ON/OFF input status is indicated on the inverter display. When set to OFF, the display will cycle through the two screens. Set as follows:



- ENABLE - activates the ON/OFF function, requiring an external contact closure to activate the inverter.
- DISABLE (default setting): disables the ON/OFF function, so that inverter operation will operate normally, depending only on grid access and sunlight.

### **UV Prot. Time (protection time)**

This function allows setting of the inverter connection time after the input voltage drops below the under voltage limit, set at 90V.

For example: If UV Prot.time is set at 60 seconds, and Vin voltage drops below 90V, the inverter stays connected to the grid (at 0 power) for up to 60 seconds afterwards.

The default value is 60 seconds, but can be set over the range of 1 s to 3,600 seconds.

### **MPPT**

This function is used to automatically set the parameters for the Maximum Power Point Tracker. Selecting this function displays the following submenus.

- MPPT Amplitude – set this parameter to choose the amplitude of the disturbance introduced in DC in order to establish the optimal work point. There are three options, LOW, MEDIUM, and HIGH. The default setting is LOW.
- Multi-Max Scan – selecting this function displays the following submenus:
  - Scan Enable/Disable - scan is Enabled by default; the scan function is used to detect if the system is on its Maximum Power Point.
  - Scan Interval - default setting is 15 minutes; set the time interval for system scan between 1-60 mins.
  - Manual Scan - select to run a manual scan and review results on the inverter display.

### **Alarm message**

Used to access to the procedure to program a user-created message that will be shown on the display in the event of a logged error code.

- Enable/Disable - message is Enabled by default.
- Compose - select Compose to create a two line message:
  - The alarm message can contain two rows of text with 16 characters each.
  - Enter text in the first line using the display keys.
  - Use UP to scroll through the numbers, letters and symbols in ascending order.
  - Use DOWN to scroll through the numbers, letters and symbols in descending order.
  - Use ENTER to move from one figure to the next (left to right).
  - Use ESC to go back to the previous position (right to left).

Continue pressing ENTER until the field for the second line appears where an additional 16 characters may be entered.

### **Reactive Power**

This menu can be used to manage the input of reactive power to the grid. From the Settings menu choose Reactive Power and scroll DOWN to select one of 5 possible types of management (Mode 0 is enabled by default).

- Mode 0 (default) - *No regulation* (Unity Power factor mode), enabled by default.
- Mode 1 - *Cos-phi fixed*: sets power factor to a fixed value.  
To enable this mode, select *Enable* and then OK (using the UP / DOWN arrows).  
When enabled, *Set percentage* will appear on the display allowing you to set the value of Cos-Phi as a percentage from 0.1 to 100.
- Mode 2 – *Q fixed*: mode sets power factor to a percentage, input in % required.



To enable this mode, select Enable and then OK (using the UP / DOWN arrows).

When enabled, *Set value* will appear on the display allowing you to set the value of Cos-Phi (either Over or Under excited from 1.000 to 0.800).

- Mode 3 -  $\text{Cos-phi} = f(P)$ : Power factor as a function of active power generated by the inverter. To enable this mode, select Enable and then OK (using the arrows). When enabled, *Use def curve* will appear on the display, allowing you to set the control curve.
- Mode 4 -  $\text{Q} = f(\text{U})$ : Reactive power as a function of the grid voltage measured by the inverter. To enable this mode, select Enable and then OK (using the UP / DOWN arrows). When enabled, *Use def curve* will appear on the display, allowing you to set the control curve.

### Power Reduction

This section of the menu is used to adjust the limits on active power which the inverter can input to the grid by setting the percentage of rated power at which the limit should be tripped. Default is 100%; value can be set from 0% to 100% in 1% steps.

## Information menu

This menu displays inverter data and enables reading and/or modification of the country standard. Part number, serial number, week/year of manufacture and firmware revision level are read only displays.

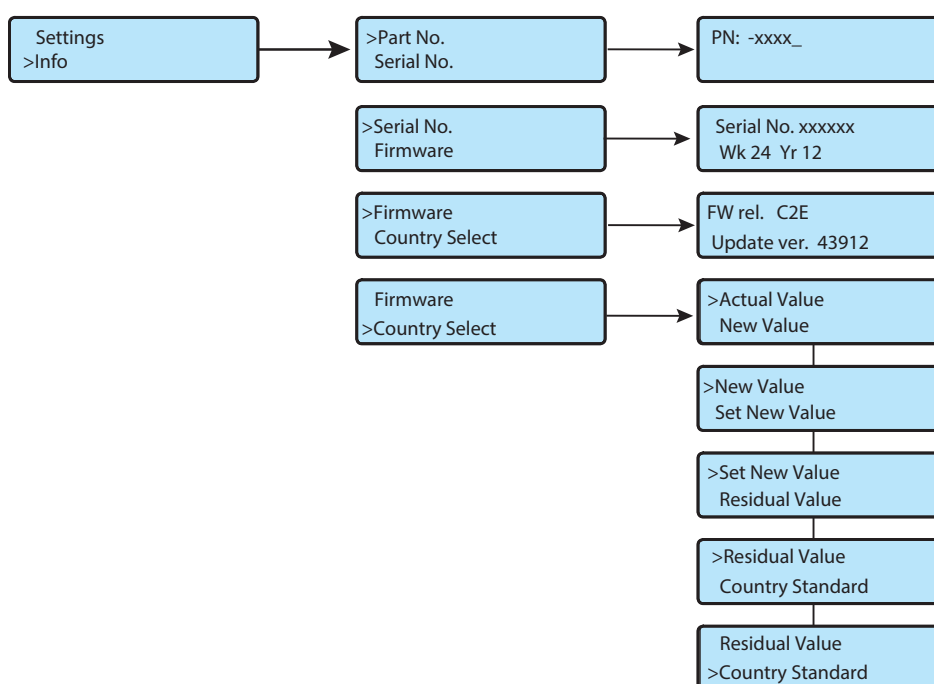
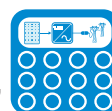

### Country Selector

This submenu allows display of the user-set grid standard currently programmed into the inverter (Current Value), and the future grid standard to be used when the inverter is next switched ON, (if a new value has been selected).

- Once a grid standard has been operating for 24 hours, the inverter control locks the selector switches (shown in Wiring, part 3).
- Changing the grid standard after the 24 hour timer has elapsed requires user to contact customer service.
- The time available for making changes to the grid standard can be confirmed by viewing Residual Time in the Country Selector submenu.

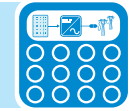

### Display messages and error codes

The equipment indicates errors/warnings on the display only if the input voltage is higher than the  $V_{dmin}$  voltage (POWER LED flashing or on; see Operations, part 4). Next to each state of the inverter, (indicated through the steady or intermittent lighting of the relevant LED), a message that identifies the operation it is carrying out or the detected fault/anomaly, is also indicated in the two-line display. Messages identify the current status of the inverter and do not relate to a fault.

When a (W) with a number after it appears in the display, it indicates a Warning Code and is usually cleared through an orderly shutdown/re-set or a self-corrective action performed by the inverter. Alarms or (E) codes identify a possible equipment failure, fault, or incorrect inverter setting or configuration. Some of the (E) codes may require technical support to assist in correcting a fault. Any and all attempts to correct or clear a fault must be performed by qualified personnel. Typically, the (E) code can be cleared once the cause or fault is removed. Some of the (E) codes may indicate a fatal error and require technical support for diagnostics and/or a product replacement.

When the red LED comes ON, try to reset the warning using the multi-function ESC button on the panel. If the inverter reconnects to the grid, the fault was due to temporary phenomena.

Display Message	Causes	Solution
Ground Fault Red LED	The alarm is generated when ground leakage current is detected in the DC section of the system. The alarm is accompanied by the lighting up of the red LED on the front of the inverter.	If possible, measure the insulation resistance using a megohmmeter positioned between the photovoltaic field (positive terminal short-circuited to the negative pole) and ground. If the measured value is less than 1 megohm, the photovoltaic array must be checked by a technician/ installer to identify and eliminate the problem. If the measured value is greater than 1 megohm and the error warning continues to be present, contact customer service.

Display Message	Causes	Solution
E001 Input OC  Input Overcurrent	The alarm appears when the inverter input current exceeds the set overcurrent threshold.	Check whether the composition of the PV array allows an input current that exceeds the maximum threshold allowed by the inverter and that the configuration of the (independent or parallel) inputs is carried out correctly. If the configuration of the PV array and the setting of the input channels are suitable, contact customer service.
E002 Input OV  Input Overvoltage	This alarm is indicated when the inverter input voltage (coming from the PV array) exceeds the operating threshold. The alarm is triggered before reaching the absolute threshold beyond which the inverter will be damaged. When the inverter input voltage exceeds the Over Voltage threshold, the inverter will generate the alarm and not start.	Measure the input voltage in the inverter with a voltmeter. If it is higher than the maximum voltage of the operating interval, the alarm is real. Check the configuration of the PV array. If it is lower than the maximum voltage of the operating interval, the alarm is caused by an internal malfunction; contact customer service.
E003 No Parameters  Internal Parameters Error	The main microcontroller is unable to correctly initialize the two DSPs (boost stage and inverter stage). This is usually due to communication problems on the internal bus of the inverter.	This is an error inside the inverter that cannot be checked externally. If the problem persists (after switching the inverter off and then on again), contact customer service.
E004 Bulk OV  Bulk Overvoltage	Error inside the inverter. The alarm is raised when the voltage at the ends of the bulk capacitors exceeds the Over Voltage threshold.	The alarm can be triggered by causes external to the inverter: an excessive inverter input voltage can be detected as a bulk overvoltage condition. In this case, it is advisable to check the inverter input voltage and, if this value is near the input OV threshold, re-examine the configuration of the photovoltaic array. The alarm can be triggered by causes internal to the inverter; If input voltage is O.K. and alarm is still present contact customer service.
E005 Comm.Error Internal Communication Error	The alarm occurs when there are communication problems between the control devices inside the inverter.	Error inside the inverter that cannot be checked externally. If the problem persists (after switching the inverter off and then on again), contact customer service.



Display Message	Causes	Solution
E006 Output OC  Output Overcurrent	The alarm appears when the inverter output current exceeds the output overcurrent threshold of the inverter.	Error inside the inverter that cannot be checked externally. If the problem persists (after switching the inverter off and then on again), contact customer service.
E007 IGBT Sat IGBT Saturation	The alarm appears when one of the active devices of the inverter is in saturation state.	Once the error appears, the inverter attempts to resume normal operation. If the error occurs sporadically, it may be caused by a sharp transition of the grid voltage or the input voltage but is not attributable to inverter malfunctioning. If the error is associated with an internal fault, it will continue to appear; contact customer service.
E009 Internal error	Error inside the inverter	Error inside the inverter that cannot be checked externally. If the problem persists (after switching the inverter off and then on again), contact customer service.
E010 Bulk Low Low Bulk Voltage	Voltage at a specific part of inverter input circuit is not sufficient for grid connection. The alarm can be triggered by causes external to the inverter: a low inverter input voltage (just above the activation voltage) that is not accompanied by sufficient availability of power from the photovoltaic array (typical condition of periods of insufficient sunlight).	If the error warning appears sporadically, it can be attributed to causes external to the inverter (insufficient sunlight, and therefore little power available from the PV array). If the problem appears systematically even in conditions of high sunlight and with input voltage significantly higher than the activation voltage, contact customer service.
E011 Ramp Fail Bulk ramp timeout	Error inside the inverter regarding the time for starting steady state operation of the DC-DC circuit part (Boost). It can be caused by an external string voltage too low or due to reduced power from PV arrays (typically in the morning).	If the alarm is present early in the morning it could be useful to increase the starting voltage to allow the grid connection of the inverter when more power is available from the PV array. If the problem persists (after switching the inverter off and then on again), contact customer service.
E012 DcDc Fail Boost module error	Error inside the inverter regarding the operation of the DC-DC circuit part (Boost).	Error inside the inverter that cannot be checked externally. If the problem persists (after switching the inverter off and then on again), contact customer service.



Display Message	Causes	Solution
E013 Wrong Mode Wrong Input Mode (parallel instead of independent)	The alarm is generated only when the inverter is configured with parallel inputs. In this particular configuration, the inverter carries out the input voltage check of each of the two channels, and the alarm is raised if the two voltages differ by more than 20Vdc.	Make sure the setting of the "IN MODE" switch has been intentionally positioned on "PAR" and that the jumpers have been inserted between the two input channels. If the configuration of the inverter is correct, check that the input strings have the same number of panels in series, of the same make and with the same inclination/orientation. If both the configuration of the inverter and the characteristics of the PV array comply with the specifications, contact customer service.
E014 Over Temp. Over-temperature	Internal inverter temperature above maximum temperature allowed. Lack of adequate ventilation in location where inverter is installed can be the cause. If ambient temperature is within the allowed range for inverter operation, the error could be due to a problem in the temperature sensors inside the inverter.	Wait for the temperatures to which the inverter is exposed to return within operating range and for the inverter to cool down. If the problem persists (once the ambient temperature has returned within the range), contact customer service. Remember to wait for the time necessary to allow the inverter to cool down.
E015 Bulk Cap Fail  Bulk capacitor failure	Error inside the inverter regarding a problem in the bulk capacitors.	Error inside the inverter that cannot be checked externally. If the problem persists (after switching the inverter off and then on again), contact customer service.
E016 Inverter Fail  Inverter module error revealed by Boost	The alarm is generated when a problem is detected in the inverter circuit part (DC/AC).	Error inside the inverter that cannot be checked externally. If the problem persists (after switching the inverter off and then on again), contact customer service.
E017 Start Timeout Inverter module start-up timeout	Error inside the inverter regarding the time for starting steady state operation of the DC-AC circuit part (Inverter). It can be caused by an external string voltage too low or due to reduced power from PV arrays (typically in the morning).	If the alarm is present early in the morning it could be useful to increase the starting voltage to allow the grid connection of the inverter when more power is available from the PV array. Error inside the inverter that cannot be checked externally. If the problem persists (after switching the inverter off and then on again), contact customer service.



Display Message	Causes	Solution
E018 Ground Fault Leakage current fail	The alarm is generated when, during normal operation of the inverter, a ground leakage current is detected in the DC section of the system. The alarm is accompanied by the lighting up of the red LED on the front of the inverter. The inverter may even also generate the E018 alarm message for AC leakage currents associated with the capacitive nature of the photovoltaic array compared to ground.	If possible, measure the insulation resistance using a megohmmeter positioned between the photovoltaic field (positive terminal short-circuited to the negative pole) and ground. If the measured value is less than 1 megohm, the PV array must be checked by a technician/installer to identify and eliminate the problem. If the measured value is greater than 1 megohm and the error warning continues to be present, contact customer service.
E019 Self-Test Error 3 Leakage current sensor self- test fail	Before connecting to the grid, the inverter carries out an autotest that tests the leakage current sensor. The test is carried out by “forcing” a current of known value in the leakage current sensor: the microprocessor compares the read value with the known value. The error is generated if the comparison between the read value and the known value during the test is not within the allowed tolerance.	This is an error inside the inverter that cannot be checked externally. If the problem persists (after switching the inverter off and then on again), contact customer service. By its nature, the alarm appears only before connection to the grid.
E020 Self-Test Error 1 Booster relay self-test fail	Before connecting to the grid, the inverter carries out some internal tests. One of these tests regards the correct operation of the boost relay. The test is carried out by “forcing” the switching of the relay and checking its functionality. The error is generated if a problem is found with the operation of the relay.	This is an error inside the inverter that cannot be checked externally. If the problem persists (after switching the inverter off and then on again), contact customer service. By its nature, the alarm appears only before connection to the grid.



Display Message	Causes	Solution
E021 Self-Test Error 2  Inverter relay self-test fail	Before connecting to the grid, the inverter carries out a test that regards the operation of the inverter relay. The test is carried out by “forcing” the switching of the relay and checking its functionality. The error is generated if a problem is found with the operation of the relay.	This is an error inside the inverter that cannot be checked externally. If the problem persists (after switching the inverter off and then on again), contact customer service. By its nature, the alarm appears only before connection to the grid.
E022 Self-Test Error 4 Relay self- test timeout	Time taken to execute the autotest carried out on the relays of the DC_AC circuit part (inverter) is too long. This may indicate a problem associated with the aforesaid relays.	Error inside the inverter that cannot be checked externally. If the problem persists (after switching the inverter off and then on again), contact customer service.
E023 DC inj error Dc-Injection out of range	The error is generated if the direct component of the current supplied to the grid exceeds the threshold of 0.5% of the rated operating current. The error does not stop the inverter, instead tries to connect to the grid again. Sporadic repetition of the error is a sign of large grid distortions or sudden changes in sunlight, whereas systematic repetition of the error warning will be a sign of an inverter fault.	If the grid voltage is strongly distorted, report this anomaly to the utility company for the resolution of the problem. If there is an inverter fault, contact customer service.
E024 Internal error	Error inside the inverter	Error inside the inverter that cannot be checked externally. If the problem persists (after switching the inverter off and then on again), contact customer service.



Display Message	Causes	Solution
E025 Riso Low Low insulation resistance	<p>Before connecting to the grid, the inverter measures the insulation resistance of the PV array compared to ground. If the insulation resistance measured by the inverter is less than 1 MOhm, the inverter does not connect to the grid and shows the “Riso Low” error. The causes may be:</p> <ul style="list-style-type: none"> <li>- Damaged PV panel(s).</li> <li>- Junction box(es) not properly sealed, allowing water and /or damp seepage ;</li> <li>- Loose connections between panels allowing humidity leakage;</li> <li>- Poor quality cable junctions;</li> <li>- Presence of unsuitable (trigger voltage lower than the characteristics of the PV array strings) or damaged overvoltage surge arresters outside the inverter in the DC section.</li> <li>- Presence of damp inside the field panel, if there is one.</li> </ul>	<p>If possible, measure the insulation resistance using a megohmmeter positioned between the photovoltaic field (positive terminal short-circuited to the negative pole) and ground (as described in the relevant section: “checking the ground insulation of the PV array”). If the measured value is less than 1 mega ohm, the photovoltaic array must be checked by a technician/installer to identify and eliminate the problem. If the measured value is greater than 1 mega ohm and the error warning continues to be present, contact customer service.</p> <p>(Damp increases leakage and can therefore be the cause of a reduction in insulation resistance).</p>
E026 Vref Error Bad internal reference voltage	Wrong measurement of the reference voltage inside the equipment.	Internal error that cannot be checked externally. If the problem persists (even after switching the inverter off and then on again), contact customer service.
E027 Error Meas V VGrid Measures Fault	Error in the internal measurement of the grid voltage (imposed by regulations) to have a measurement redundancy (2 measurements on the same parameter carried out by two different circuits).	This is an error inside the inverter that cannot be checked externally. If the problem is persistent (even after switching the inverter off and then on again), contact customer service.



Display Message	Causes	Solution
E028 Error Meas F FGrid Measures Fault	Error in the internal measurement of the grid frequency (imposed by regulations) to have a measurement redundancy (2 measurements on the same parameter carried out by two different circuits).	This is an error inside the inverter that cannot be checked externally. If the problem is persistent (even after switching the inverter off and then on again), contact customer service.
E029 Error Meas Z ZGrid Measures Fault	Error in the internal measurement of the insulation resistance of the PV array compared to ground (imposed by regulations) to have a measurement redundancy (2 measurements on the same parameter carried out by two different circuits).	Error inside the inverter that cannot be checked externally. The error occurs if the internal measurement is carried out before connection to the grid) If the problem is persistent (even after switching the inverter off and then on again), contact customer service.
E030 Error Meas Ileak Ileak Measures Fault	Error in the internal measurement (carried out when the inverter is connected to the grid) of the leakage current of the DC side (PV array) compared to ground (imposed by regulations) to have a measurement redundancy (2 measurements on the same parameter carried out by two different circuits).	This is an error inside the inverter that cannot be checked externally. If the problem is persistent (even after switching the inverter off and then on again), contact customer service.
E031 Error Read V Wrong V Measure	Measurement of the internal voltage at the ends of the output relay out of range. There is too great a difference in voltage between the input and the output of the output relay that can be caused by grid voltage instability.	Check the grid conditions for instabilities caused by switch of heavy loads or reactive loads (like motors, welding machines etc.). If the problem appears repeatedly, contact customer service.
E032 Error Read I Wrong I Measure	Measurement of the output voltage unbalance (carried out between the three phases) out of range (only in three-phase models).	This is an error inside the inverter that cannot be checked externally. If the problem appears repeatedly contact customer service.



Display Message	Causes	Solution
E033 UTH Under Temperature	Alarm is triggered when internal temperature is below low temperature threshold. Depending where the inverter is located, ambient temperature can reach values below UT limits. In case in which ambient temperature is above that UTH limits, a failure of the temp sensing circuitry is occurred.	Wait for the temperatures to which the inverter is exposed to return within operating range. If the problem persists, contact customer service. Remember to wait for the time necessary to allow the inverter to warm up.
E034 Interlock fail IGBT not ready	Error inside the inverter	Error inside the inverter that cannot be checked externally. If the problem persists (after switching the inverter off and then on again), contact customer service.
E035 Remote Off Waiting remote ON	The inverter has been switched off remotely (remote OFF) and remains in waiting state for the signal that will switch it on again (remote ON).	Switch on the inverter remotely. If the unit does not switch on, disable the remote on/off function and switch the equipment off completely and then switch it on again. If the problem persists (after re-enabling the Remote ON/ OFF function from the display), contact customer service.
E036 Vout Avg error  Average Vout out of range	The average grid voltage value (every 10 minutes) does not fall within the allowed ranges. The grid voltage at the point connected to the inverter is too high. This may be caused by grid impedance that is too high. Towards the end of the timeout, the inverter limits the power to check whether the grid voltage stabilizes within the normal parameters. If this does not happen, the inverter disconnects from the grid.	Check the grid voltage at the inverter connection point. If the grid voltage diverges from the range because of grid conditions, ask the grid company to adjust the grid voltage. If the grid company authorizes a change to the inverter parameters, arrange the new limits with customer service.



Display Message	Causes	Solution
E037 Riso Low  Low insulation resistance (amorphous mode only)	This error can appear only if the “Amorphous” mode is enabled. This function is enabled only in inverters equipped with grounding kit and is used to monitor the voltage at the ends of the grounding resistor. The error appears when the voltage at the ends of the resistor connected between ground and pole of the photovoltaic array exceeds 30V for more than 30 minutes or 120V for more than one second.	Check for the presence and correct contacting of the two terminals of the grounding resistor installed inside the inverter. If possible, measure the insulation resistance using a megohmmeter positioned between the PV field (positive terminal short-circuited to the negative pole) and ground (as described in the operation chapter). If the measured value is less than 1 mega ohm, the photovoltaic array must be checked by a technician/ installer to identify and eliminate the problem. If the measured value is greater than 1 mega ohm and the error warning continues to be present, contact customer service.
Mid Bulk OV E038 Mid bulk OV	NA	NA
E050 Arc Fault (-A version ONLY) DC Arc detected	An electrical arc has been detected on DC cables. This error latches the inverter in a disconnected state	Check DC cables and connections to identify the source of possible arcing. Press ESC as indicated in the display in order to unlatch the inverter.
E053 AF Self-Test (-A version ONLY) Arc fault detector (AFD) sensor Self-test failed	Self-Test performed by AFD board failed. The board will try another self-test after user turns inverter off and on.	Press ESC as indicated in the display in order to unlatch the inverter. If the problem persists (after switching the inverter off and on), contact customer service.
E056 Over Temp. (from external box)	Excessive temperature measured inside the inverter’s wiring box: High internal temperature. This error relates to the temperature measured on external boxes.	Check that the inverter is not exposed to direct sunlight. Wait for the temperatures to which the inverter is exposed to return to the operating range and for the inverter to cool down. If the problem persists (once the ambient temperature has returned to the range), contact customer service.





Display Message	Causes	Solution
E057 Vbulk reading error	Input voltage ( $V_{in}$ ) higher than booster voltage ( $V_{bulk}$ ): The error occurs if the input voltage exceeds the Bulk voltage (voltage on the DC-DC circuit inside the inverter)	Measure the input voltage inside the inverter with a voltmeter. If it is higher than the maximum voltage of the operating range, it is necessary to check the configuration of the PV array. If the voltage has also exceeded the maximum input threshold the inverter could be damaged. If it is lower than the maximum voltage of the operating range, the alarm is caused by an internal malfunction and it is necessary to contact customer service.
E058 Pin vs. Pout check error	The error occurs if the difference between the measured value of input power and that of output power is greater than the limit imposed internally to the inverter.	Error inside the inverter that cannot be checked externally. If the problem persists (after switching the inverter off and then on again), contact customer service.
W001 Sun Low (Low input voltage during switch-on of the inverters)	Insufficient sunlight. Wrong configuration of the PV array or a configuration “at the limit” as regards the minimum input voltage of the inverter.	Check the inverter input voltage. If it does not exceed the $V_{start}$ , check that there is sufficient sunlight and that the composition of the system is correct. If it exceeds the $V_{start}$ , contact customer service.
W002 Input UV (Low input voltage during switch-off)	Insufficient sunlight Wrong configuration of the photovoltaic array or a configuration “at the limit” as regards the minimum input voltage of the inverter.	Check the inverter input voltage. If it does not exceed the $V_{start}$ , check that there is sufficient sunlight and that the composition of the system is correct. If it exceeds the $V_{start}$ , contact customer service.



Display Message	Causes	Solution
<p>W003 Grid Fail</p> <p>Grid Fail (grid voltage parameters outside the limits)</p>	<p>This error warning appears during normal operation of the inverter when the grid parameters fall outside the limits set by the grid company.</p> <p>No grid voltage (after the warning, the inverter goes on “No Vac”) Unstable grid voltage (downwards and upwards) Unstable grid frequency.</p>	<p>Check the grid voltage on the inverter. If absent, check for the absence of grid voltage on the supply. If the voltage tends to rise (when the inverter is connected), it means there are high line or grid impedances. Check the grid voltage on the supply as well; if it is high, it means there is high grid impedance. In this case, ask the grid company to adjust the grid voltage. If the grid company authorizes a change to the inverter parameters, arrange the new limits with the customer service.</p> <p>If the voltage at the supply point is much lower than that measured on the inverter, the line must be adjusted (inverter-counter). If the grid voltage and frequency fall within the limits (even when the inverter is connected to the grid), contact customer service.</p>
<p>W009 Table fail</p>	NA	NA
<p>W010 Fan Fail (Alarm not shown on the display; there is only a flashing yellow LED)</p>	<p>This error appears when there is malfunctioning of the fan(s) inside the inverter. In this condition, the yellow LED on the front panel flashes.</p>	<p>Error inside the inverter that cannot be resolved with external operations. If the alarm is persistently repeated, contact customer service.</p>
<p>W011 Bulk UV</p>	<p>Reading of the internal voltage on the bulk capacitors carried out when the inverter is connected to the grid.</p>	
<p>W012 Battery low</p> <p>Low internal clock battery voltage</p>	<p>Internal battery for maintenance of the date/time settings is discharged or damaged.</p>	<p>Replace the battery with the inverter completely switched off (disconnect AC side and DC side) and be sure to observe the correct polarity.</p>
<p>W013 Clk fail</p> <p>Internal clock failure</p>	<p>The alarm appears when the time shown on the display differs by more than 1 minute from the internal time of the microprocessors and indicates clock circuit malfunctioning.</p>	<p>This is an error inside the inverter that cannot be resolved with external operations. If the alarm is persistently repeated, contact customer service.</p>

Display Message	Causes	Solution
W017 Jbox fail  Fuse-control board fail (DC string fail)	Fuse(s) on the fuse boards is/are damaged.	Using a multimeter, check the condition of the fuses (situated on the fuse boards). Replace any open fuses and check that the input current on the string(s) does not exceed the rating of the fuses (if string parallels have been made outside the inverter). If there are no damaged string fuses and the inverter continues to display the alarm message, check whether the settings to be made through the Aurora Manager software are correct (presence or absence of one or more input strings).
W018 SPD DC protection open	Overvoltage surge arresters situated on the DC side are damaged.	Look at the inspection window present on each surge arrester (DC side). If it is red, the surge arrester is damaged and the cartridge must be replaced. If the alarm status continues to be present even though all the surge arresters have a green inspection window, contact customer service.
W019 SPD AC protection open	Overvoltage surge arresters situated on the AC side are damaged.	Look at the inspection window present on each surge arrester (AC side). If it is red, the surge arrester is damaged and the cartridge must be replaced. If the alarm status continues to be present even though all the surge arresters have a green inspection window, contact customer service.
W022 Reactive power mode changed notification only	Variation in the means of managing reactive power; this change is made through the display or advanced configuration software.	Notification of change that is saved in the historical log of inverter events.
W023 Date/time changed notification only	Variation of the inverter's date and time; this change is made through the display or advanced configuration software.	Notification of change that is saved in the historical log of inverter events.



Display Message	Causes	Solution
W024 Energy data reset notification only	Zeroing of the statistical energy data stored in the EEPROM: Reset of the energy data saved in the inverter; this operation can be handled through the display or advanced configuration software.	Notification of change that is saved in the historical log of inverter events.  The notice may also occur on substitution of the Memory Card where the statistical production data is saved.

## Making a service call

Call technical support at 877-261-1374. The following information is necessary to initiate a call. The model number, serial number, and week of production can be found on the INFORMATION menu of the inverter display and on the product label:

Model number  
Serial number  
Week of production

State of LED:

- Status of light(s)
- Steady or flashing
- Error message or code

Identify the System structure:

- Information on the Photovoltaic Field
- Brand and model of photovoltaic panels
- Maximum array voltage and current values
- Number of strings in the array
- Number of panels for each string

Provide a description of the conditions:

- Can the fault be reproduced? If so, how?
- Is the fault cyclical in nature? If so, how often?
- Was the fault apparent at the time of installation? If so, has it worsened?
- Describe the atmospheric conditions at the time the fault appears/appeared

### Shut-down procedure

Once the inverter is wired and connected to the grid use the following procedures to disconnect for maintenance.



**Before performing any operation on the switchbox power input, ALWAYS perform the appropriate disconnection procedure outlined below.**

**To avoid the risk of electric shock from energy stored in capacitors, wait at least ten minutes after disconnecting both AC and DC sides before opening the front panel.**

There are three options for shutting down the inverter:

1. Disconnect the DC and the AC grid, by disconnecting its associated switches (in any order). The inverter will shut down within a few seconds necessary to discharge the internal capacitors.
2. Disconnect the DC input by turning OFF the associated disconnect switch and waiting for the UV port time setting to time out.
3. Disconnect the grid, by turning-OFF its associated disconnect switch when the DC input is less than 80 Vdc.

### Routine maintenance

Checking and maintenance operations must be carried out by specialized staff assigned to carry out this work. DO NOT allow the equipment to be used if problems of any kind are found, and restore the normal conditions correctly or make sure this is done.



*Maintenance operations must be carried out with the equipment disconnected from the grid, unless otherwise indicated.*

*For cleaning, DO NOT use rags made of filamentary material or corrosive products that may corrode parts of the equipment or generate electrostatic charges.*

*Always use the personal protective equipment provided by the employer and comply with the safety conditions in Part 1 of this manual.*

The table below describes routine maintenance recommended to maintain efficient operation of the installation.

Annual visual inspection	Check that all labels and safety symbols are visible; Check that the environmental conditions have not changed drastically (exposure to weather condition); Check that the inverter has not been shaded or isolated by foreign bodies.
Annual operations	Check the tightness of the cable opening plugs; Check the fitting of the connectors and front covers (loose fittings can allow water seepage into the cabinet which may result in short circuits due to humidity).
Annual cleaning	Clean the equipment; verify that no obstructions are present on the fins of the heat sink. If possible, use an extractor or suitable pipe cleaners.

## Replacing the CR2032 battery

The CR2032 battery, located on the inverter connection board, powers the time of day clock. When this battery is at end-of-life, a message will appear in the display alerting the need for replacement. The battery should only be replaced by qualified personnel.

- Refer to Wiring, part 3, for the procedure to remove the front panel and location of the battery on the inverter connection board.
- To insert the new battery into its holder, slide the battery at a 30° angle pushing it into insertion as shown at right.
- When pushed into place it should seat into the correct position within the holder.

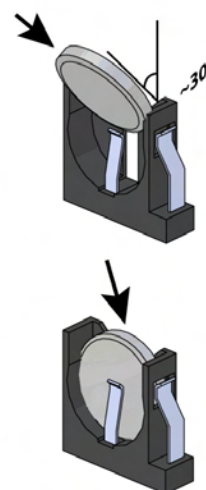

## Ground fault detector fuse replacement



*Normally grounded conductors may be ungrounded and energized when a ground-fault is indicated resulting in risk of electric shock. Always test before touching.*

- The GFD fuse holder is located on the bottom of the inverter for the standard version with no switchbox and inside the switchbox on the upper left for -S1 and -S2- models.
- Unscrew the fuse holder in order to replace the fuse.
- Replace only with: Littelfuse KLKD-1 (10x38mm cartridge fuse, 600V)





## Storage and dismantling

If the equipment is not used immediately or is stored for long periods, check that it is packaged correctly and contact customer service for storage instructions. The equipment must be stored in well-ventilated indoor areas in a noncorrosive environment. Restarting after a long period requires the removal of oxidation and dust that may have settled inside the equipment if not suitably protected.

ABB CANNOT be held responsible for disposal of the equipment, displays, cables, batteries, etc. The customer must dispose of these substances, which are potentially harmful to the environment, in accordance with the regulations in force in the country of installation.

If the equipment is dismantled, follow the regulations in force in the country of destination and avoid causing any kind of pollution upon disposal. Use dumps suitable for disposal of the various types of materials listed below.

<u>COMPONENT</u>	<u>MATERIAL OF CONSTRUCTION</u>
Frame, brackets, supports	Arc-welded steel FE37
Casing or covers	ABS, plastic
Paint and	RAL
Gaskets and seals	Rubber / Teflon / Viton
Electrical cables	Copper / Rubber
Conduits	Polyethylene / Nylon
Back-up battery	Nickel / Lead/ Lithium





## System description

ABB grid-tied inverters provide the capability to supply the utility grid with energy obtained from PV panels. To use the DC generated by a Photovoltaic field efficiently, it must be transformed into alternating current (AC) via a conversion process known as DC-AC inversion.

This process is the basis of all grid-tied inverters and is achieved very efficiently by the inverter without the use of rotating elements. When the inverter output is connected in parallel to the utility power grid, the alternating current output from the inverter flows directly into the distribution circuit, and is connected in turn to the public distribution utility grid.

The photovoltaic energy system can thus feed all the connected user electrical loads:

- If the energy supply from the photovoltaic system is lower than the user's load requirement, the quantity of energy necessary to guarantee normal functioning of the connected appliances is taken from the public distribution network.
- If the energy supply from the photovoltaic system is greater than the user's load requirement (i.e. an excess of energy is produced) it is sent directly into the public network, becoming available to other users.

Depending on prevailing codes and regulations of the installation area, the energy produced can be sold to the utility or credited against future consumption, producing energy savings.

### **Strings and arrays**

A photovoltaic panel consists of many photovoltaic cells mounted on the same support. A string consists of a certain number of panels connected in series. An array consists of two or more strings connected in parallel.

Large photovoltaic systems can be made up of several arrays, connected to one or more inverters. By maximizing the number of panels inserted into each string, the string output voltage is increased, which reduces the cost and complexity of the photovoltaic system. The current of each array must fall within the limits of the inverter.

### **Connection of several inverters together**

If the photovoltaic system exceeds the capacity of a single inverter, it is possible to make a multiple connection of inverters to the system, with each one connected to a suitable section of the photovoltaic field, on the DC side, and connected to the grid on the AC side.

Each inverter with multiple strings will work independently of the others and will supply the grid with the maximum power available from its section of photovoltaic panels.

### **Notes on the sizing of the system**

Decisions about how to structure a photovoltaic system depend on a certain number of factors and considerations to make, such as for example, the type of panels, the availability of space, the future location of the system, energy production goals over the long term, etc.

A configuration program that can help to correctly size the photovoltaic system is available on the website.

## **Protective devices within the inverter**

### **Anti-Islanding**

In accordance with required national standards and laws, in the event of a local grid outage by the utility, or when the grid equipment is switched OFF for maintenance operations, the inverter must be physically and safely disconnected, to ensure protection of personnel working on the grid. To prevent possible islanding, the inverter has an automatic protective disconnection system called “Anti-Islanding”.

### **Ground fault in the photovoltaic panels**

An advanced ground fault protection circuit continuously monitors the ground connection and disconnects the inverter when a ground fault occurs, indicating this condition by means of the red GFI on the LED panel.

### **Further protective devices**

The inverter is equipped with additional protective devices to guarantee safe operation in any circumstance. These protective devices include:

- Continuous monitoring of the grid voltage to ensure the voltage and frequency values stay within operating limits;
- Control of internal temperatures to automatically limit the power if necessary to ensure the unit does not overheat (derating).



## **Block diagram**

The figure below shows the block diagram for the inverter. The main blocks are the input DC-DC converters (termed ‘boosters’) and the output inverter. Both the DC-DC converters and the output inverter operate at a high switching frequency to enable a compact design and relatively low weight. These versions have a high frequency transformer, i.e. with galvanic insulation between input and output. The high frequency transformer allows the primary (DC side) to have galvanic isolation from the secondary (AC side).

The block diagrams on the next page show PVI-10.0-I-OUTD and PVI-12.0-I-OUTD with two independent input DC-DC converters; each converter is dedicated to a separate array with independent Maximum Power Point Tracking (MPPT) control. This means that the two arrays can be installed with different positions and facing different directions. Each array is controlled by an MPPT control circuit.

The inverter is controlled by two independent Digital Signal Processors (DSP) and one central microprocessor. This way, network connection is controlled by two independent computers in full compliance with electrical power supply and safety regulations. The inverter operating system communicates with the related parts to perform data processing. This guarantees optimal performance levels of the whole complex and high yield in all insulation and load conditions, always in full respect of directives, laws and provisions.

## Block diagram of PVI-10.0-I-OUTD

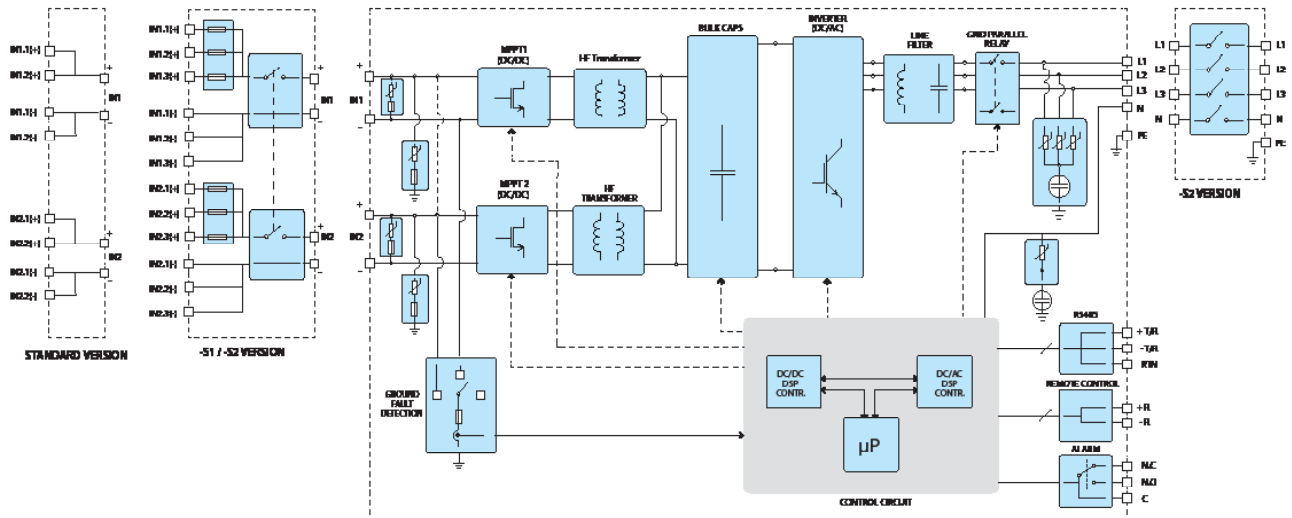

## Block diagram of PVI-12.0-I-OUTD

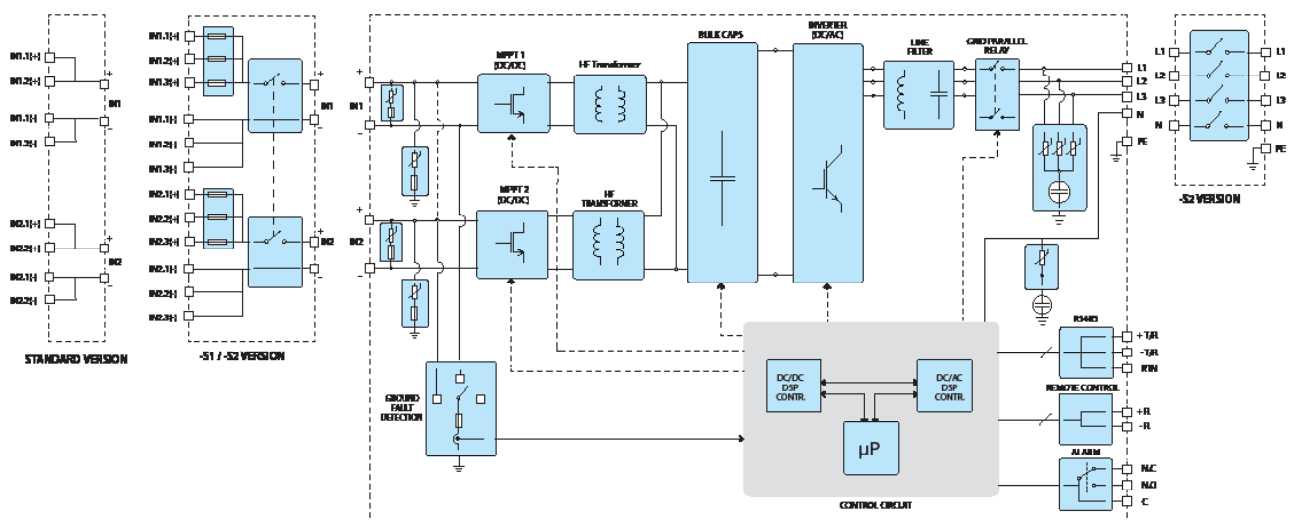

## Efficiency curves

The equipment was designed in compliance with energy conservation standards to avoid waste and unnecessary leakage. Graphs of the efficiency curves of the inverters are shown below. The efficiency curves are affected by technical parameters that are continually being developed and improved and should be considered approximate. \*Efficiency shown for inverters operating at 408Vac.

### PVI-10.0-I

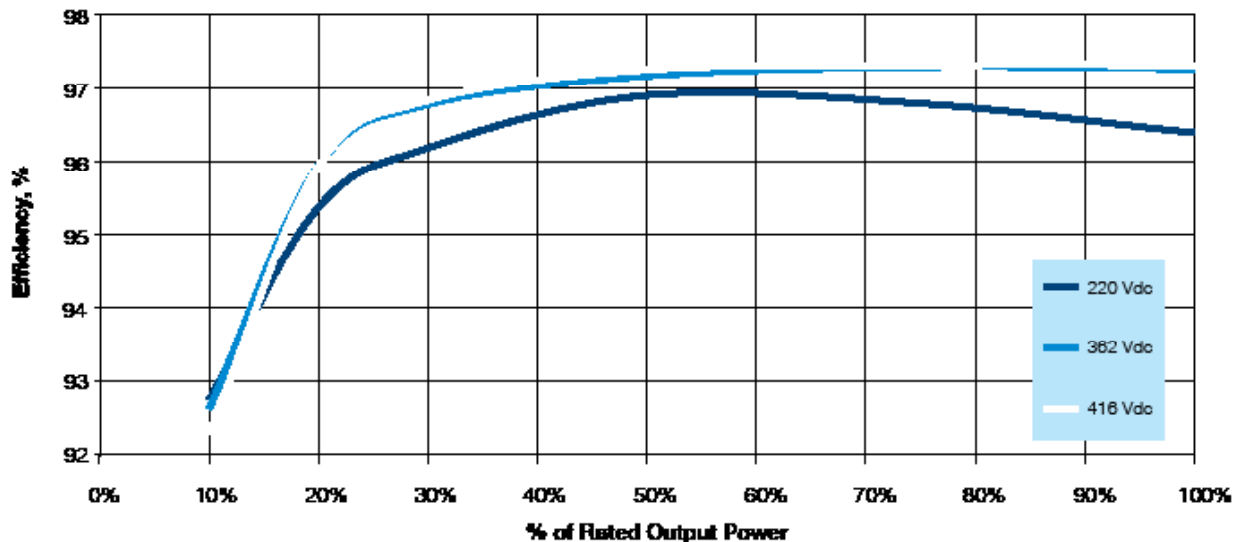

### PVI-12.0-I

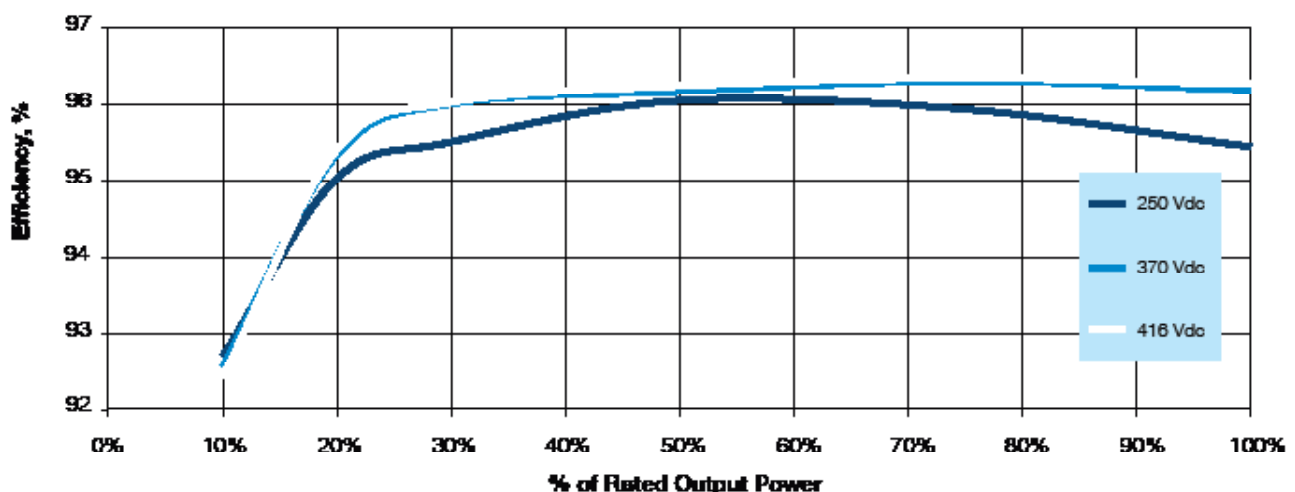

## Power derating curves

In order to ensure reliable operation under different ambient and loading conditions, the inverter automatically decreases the output power as a function of the temperature and input voltage.

### Power reduction due to temperature

Power reduction and temperature at which it occurs depend on many parameters other than ambient temperature, such as input voltage, grid voltage, etc. The inverters can thus decrease power output during

certain periods of the day according to these parameters. The inverters deliver full output power up to 40°C ambient as long as they are not directly exposed to sunlight or other heat sources. The following graphs show the automatic reduction in output power in relation to ambient temperature over range -25° to +60°C:

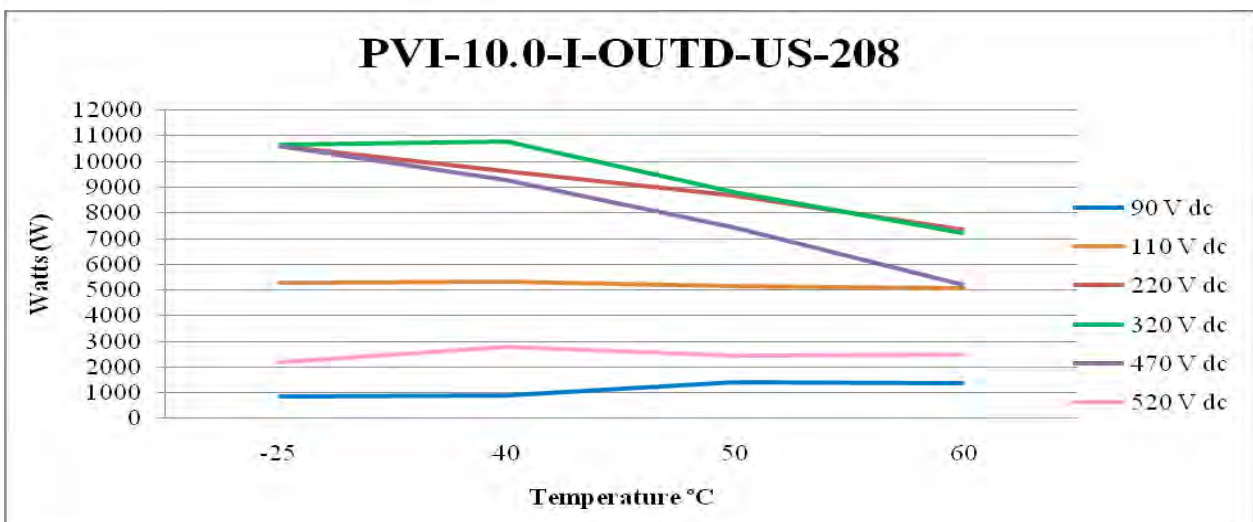
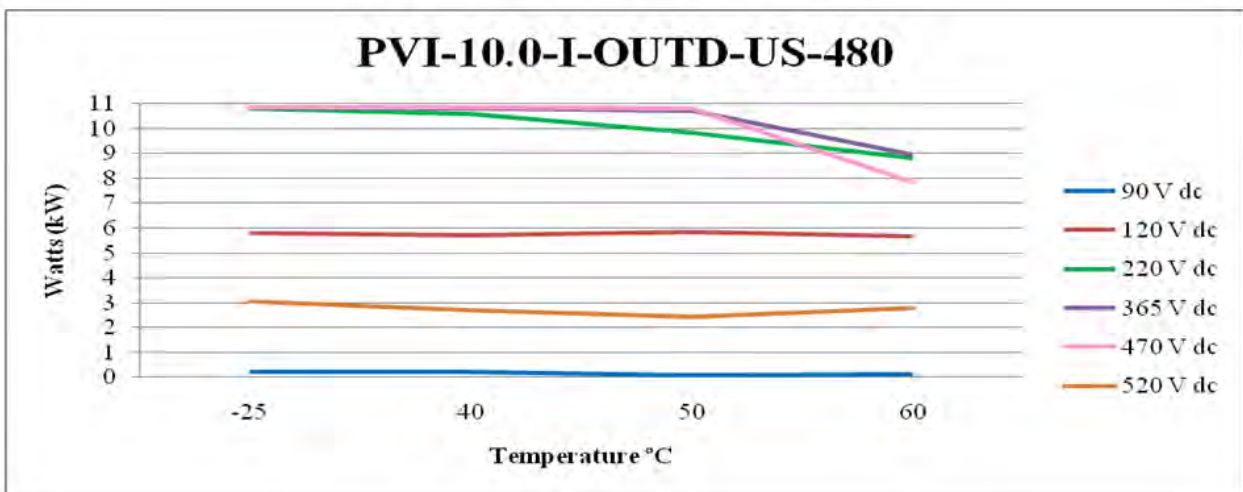
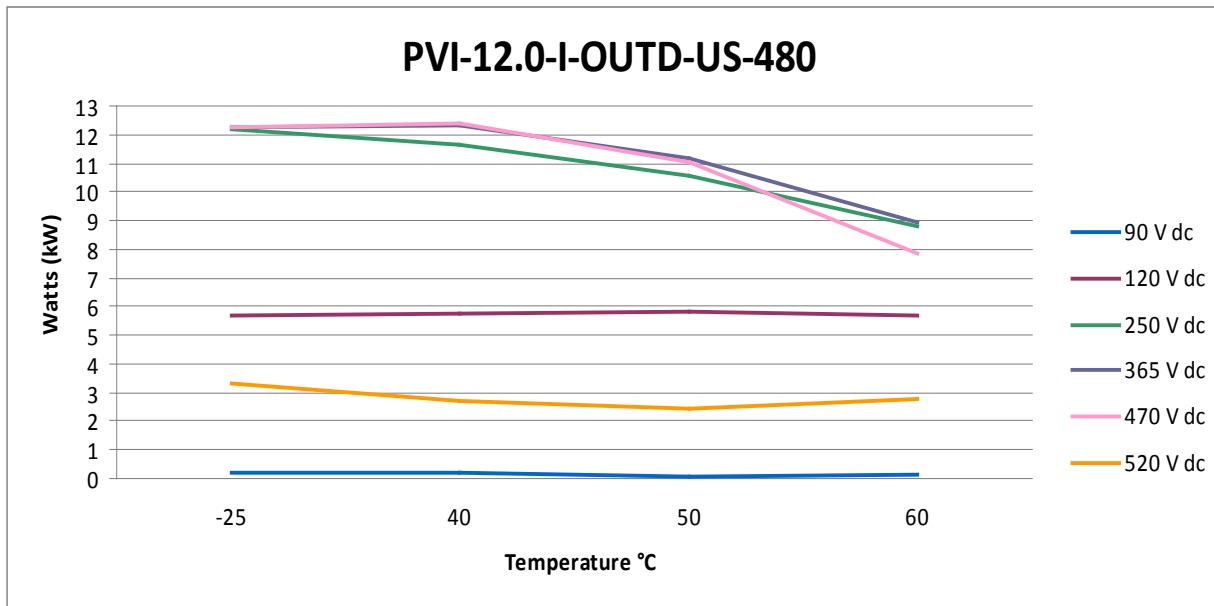

**Power reduction due to input voltage**

Power derating due to environmental conditions and to the input voltage can occur at the same time and the available output power is determined as a lower of the two numbers.





# Technical data and types PVI-10-I-OUTD

Type code	PVI-10.0-I-OUTD-US			PVI-10.0-I-OUTD-CAN	
Nominal output power	10000W	10000W	10000W	10000W	10000W
Maximum output power	11000W*	11000W*	10000W*	10000W*	10000W*
Rated grid AC voltage	208V	480V	208V	480V	600V
<b>Input side (DC)</b>					
Number of independent MPPT Channels	2; programmable for 1 MPPT				
Maximum usable power for each MPPT channel	6800W				
Absolute maximum voltage (Vmax)	520V				
Start-up voltage (Vstart)	200V (adj. 120V min.)				
Full power MPPT voltage range	220-470V				
Operating MPPT voltage range	0.7 x Vstart - 520				
Maximum current (I <sub>dcmax</sub> ) for both MPPT in parallel	48A				
Maximum usable current per MPPT channel	24A				
Maximum short circuit current (I <sub>sc max.</sub> ) per MPPT channel	29A				
Maximum short circuit current (I <sub>sc max.</sub> ) for both MPPT in parallel	58A				
Number of inputs (strings) per MPPT channel	Standard version: 2; -S1 version: 3; -S2 version: 3				
Array wiring termination type	Terminal block, pressure clamp, 20AWG-6AWG				
<b>Output side (AC)</b>					
Grid connection type	3Ø/3W or 4W + Ground				
Default voltage range	183-228V	422-528V	183-228V	422-528V	528V-660V
Nominal grid frequency	60Hz				
Adjustable grid frequency range	57-63 Hz				
Maximum Current (I <sub>ac max/phase</sub> )	30.0A <sub>RMS</sub>	14.0A <sub>RMS</sub>	30.0A <sub>RMS</sub>	14.0A <sub>RMS</sub>	10.6A <sub>RMS</sub>
Power factor	>0.995 (adj. ±0.9)				
Total harmonic distortion (at rated power)	<2%				
Grid wiring termination type	Terminal block, pressure clamp, 12AWG-4AWG				
Fault current	44.4A <sub>RMS</sub>	30.6A <sub>RMS</sub>	44.4A <sub>RMS</sub>	30.6A <sub>RMS</sub>	18.65A <sub>RMS</sub>
<b>Input protection devices</b>					
Reverse polarity protection	Yes				
Over-voltage protection type	Varistor, 2 for each channel				
PV array ground fault detection	GFDI (GFD fuse) per UL 1741/ NEC 690.5				
<b>Output protection devices</b>					
Anti-islanding protection	Meets UL 1741/IEEE1547 requirements				
Over-voltage protection type	1 varistor per line (3), 1 gas arrester to PE				
<b>Efficiency</b>					
Maximum efficiency	96.5%	97.3%	96.5%	97.3%	97.3%
CEC efficiency	96.0%	97.0%	96.0%	97.0%	97.0%
<b>Operating parameters</b>					
Feed-in power threshold	30W <sub>RMS</sub>				
Stand-by consumption	< 8W <sub>RMS</sub>				
<b>Communication</b>					
User-interface (display)	16 characters x 2 lines LCD display				
Standard communication interfaces	(1) RS485 connection. Standard Aurora protocol. Optional Modbus				
Optional remote monitoring logger	VSN 700 Data Logger				
<b>Environmental</b>					
Ambient air operating temperature range	-13°F to +140°F (-25°C to +60°C) Derating above +104°F (+40°C)	-13°F to +140°F (-25°C to +60°C) Derating above +122°F (+50°C)	-13°F to +140°F (-25°C to +60°C) Derating above +104°F (+40°C)	-13°F to +140°F (-25°C to +60°C) Derating above +122°F (+50°C)	-13°F to +140°F (-25°C to +60°C) Derating above +113°F (+45°C)
Ambient storage temperature range	-40°F to +176°F (-40°C to +80°C)				
Relative humidity	0-100 % condensing				
Acoustic noise emission level	<50 db (A) @ 1m				
Maximum operating altitude without derating	6560ft (2000m)				
<b>Mechanical specifications</b>					
Enclosure rating	NEMA 4X				
Cooling	Natural convection				
Dimensions (H x W x D)	Standard: 28.2 x 25.4 x 8.7in / 716 x 645 x 222mm -S1, -S2 version: 37.7 x 25.4 x 8.7in / 958 x 645 x 222mm				
Unit weight	Standard: 101lbs (45.8kg); -S1: 107 lbs (48.5kg); -S2: 114lbs (51.7kg)				
Shipping weight	With pallet: 254lbs (<115kg); without pallet: 143lbs (<65kg)				
Conduit connections	Bottom: (1) 1/2" KO, (2) 1" pluggable opening, (4) 1/2" pluggable openings / Left and Right Side: (1) Concentric KO 3/4", 1" Back: (4) Concentric KO 3/4", 1"				
Mounting system	Wall bracket				
Ground fault detector fuse size/type	1A / 600V 10 x 38mm				
Optional string combiner fuse size/type (-S1 and -S2)	15A / 600V 10mm x 38mm				
Optional DC switch current rating (per contact)	32A				
<b>Safety</b>					
Isolation level	Isolated - High frequency transformer				
Safety and EMC standard	UL 1741, IEE1547, IEE1547.1, CSA-C22.2N. #107.1-01				
Safety Approval	cCSAus				
<b>Warranty</b>					
Standard warranty	10 years				
Extended Warranty	15 & 20 years				
<b>Available models</b>					
Standard	PVI-10.0-I-OUTD-US-208-NG	PVI-10.0-I-OUTD-US-480-NG	PVI-10.0-I-OUTD-CAN-208-NG	PVI-10.0-I-OUTD-CAN-480-NG	PVI-10.0-I-OUTD-CAN-600-NG
With DC switch and DC fuses	PVI-10.0-I-OUTD-S1-US-208-NG	PVI-10.0-I-OUTD-S1-US-480-NG	PVI-10.0-I-OUTD-S1-CAN-208-NG	PVI-10.0-I-OUTD-S1-CAN-480-NG	PVI-10.0-I-OUTD-S1-CAN-600-NG
With AC and DC switches and DC fuses	PVI-10.0-I-OUTD-S2-US-208-NG	PVI-10.0-I-OUTD-S2-US-480-NG	PVI-10.0-I-OUTD-S2-CAN-208-NG	PVI-10.0-I-OUTD-S2-CAN-480-NG	PVI-10.0-I-OUTD-S2-CAN-600-NG

\*Capability enabled at nominal AC voltage and with sufficient DC power available  
Information in this document is subject to change without notice

# Technical data and types PVI-12-I-OUTD

Type code	PVI-12.0-I-OUTD-US		PVI-12.0-I-OUTD-CAN	
Nominal output power	12000W		12000W	
Maximum output power	13200W*		12000W*	
Rated grid AC voltage	480V		480V	600V
<b>Input side (DC)</b>				
Number of independent MPPT channels	2; programmable for 1 MPPT			
Maximum usable power for each MPPT channel	6800W			
Absolute maximum voltage (Vmax)	520V			
Start-up voltage (Vstart)	200V (adj. 120V min.)			
Full power MPPT voltage range	250-470V			
Operating MPPT voltage range	0.7 x Vstart - 520			
Maximum current (I <sub>dcmax</sub> ) for both MPPT in parallel	50A			
Maximum usable current per MPPT channel	25A			
Maximum short circuit current (I <sub>sc max.</sub> ) per MPPT channel	29A			
Maximum short circuit current (I <sub>sc max.</sub> ) for both MPPT in parallel	58A			
Number of inputs (strings) per MPPT channel	Standard version: 2; -S1 version: 3; -S2 version: 3			
Array wiring termination type	Terminal block, pressure clamp, 20AWG-6AWG			
<b>Output side (DC)</b>				
Grid connection type	3Ø/3W or 4W + Ground			
Default voltage range	422V-528V	422V-528V	528V-660V	
Nominal grid frequency	60Hz			
Adjustable grid frequency range	57-63 Hz			
Maximum current (I <sub>ac max/phase</sub> )	16.0A <sub>RMS</sub>	16.0A <sub>RMS</sub>	12.8A <sub>RMS</sub>	
Power factor	>0.995 (adj. ±0.9)			
Total harmonic distortion (at rated power)	<2%			
Grid wiring termination type	Terminal block, pressure clamp, 12AWG-4AWG			
Fault current	30.6A <sub>RMS</sub>	30.6A <sub>RMS</sub>	18.65A <sub>RMS</sub>	
<b>Input protection devices</b>				
Reverse polarity protection	Yes			
Over-voltage protection type	Varistor, 2 for each channel			
PV array ground fault detection	GFDI (GFD fuse) per UL 1741/ NEC 690.5			
<b>Output protection devices</b>				
Anti-islanding protection	Meets UL1741 / IEEE1547 requirements			
Over-voltage protection type	1 varistor per line (3), 1 gas arrester to PE			
<b>Efficiency</b>				
Maximum efficiency	97.3%			
CEC efficiency	97.0%			
<b>Operating parameters</b>				
Feed-in power threshold	30W <sub>RMS</sub>			
Stand-by consumption	< 8W <sub>RMS</sub>			
<b>Communication</b>				
User-interface (display)	16 characters x 2 lines LCD display			
Standard communication interfaces	(1) RS485 connection. Standard Aurora protocol. Optional Modbus			
Optional remote monitoring logger	VSN 700 Data Logger			
<b>Environmental</b>				
Ambient air operating temperature range	-13°F to +140°F (-25°C to +60°C) Derating above +113°F (+45°C)			
Ambient storage temperature range	-40°F to +176°F (-40°C to +80°C)			
Relative humidity	0-100% condensing			
Acoustic noise emission level	< 50 db (A) @1m			
Maximum operating altitude without derating	6560 ft (2000 m)			
<b>Mechanical specifications</b>				
Enclosure rating	NEMA 4X			
Cooling	Natural convection			
Dimensions (H x W x D)	Standard: 28.2 x 25.4 x 8.7in / 716 x 645 x 222mm -S1, -S2 version: 37.7 x 25.4 x 8.7in / 958 x 645 x 222mm			
Unit weight	Standard: 101lbs (45.8kg); -S1: 107lbs (48.5kg); -S2: 114lbs (51.7kg)			
Shipping weight	With pallet: 254lbs (<115kg); without pallet: 143lbs (<65kg)			
Conduit connections	Bottom: (1) 1/2" KO, (2) 1" pluggable opening, (4) 1/2" pluggable openings / Left and Right Side: (1) Concentric KO 3/4", 1" / Back: (4) Concentric KO 3/4", 1"			
Mounting system	Wall bracket			
Ground fault detector fuse size/type	1A / 600V 10 x 38mm			
Optional string combiner fuse size/type	15A / 600V 10mm x 38mm			
Optional DC switch current rating (per contact)	32A			
<b>Safety</b>				
Isolation level	Isolated - High frequency transformer			
Safety and EMC standard	UL 1741, IEE1547, IEE1547.1, CSA-C22.2N. #107.1-01			
Safety Approval	cCSAus			
<b>Warranty</b>				
Standard warranty	10 years			
Extended warranty	15 & 20 years			
<b>Available models</b>				
Standard	PVI-12.0-I-OUTD-US-480-NG	PVI-12.0-I-OUTD-CAN-480-NG	PVI-12.0-I-OUTD-CAN-600-NG	
With DC switch and DC fuses	PVI-12.0-I-OUTD-S1-US-480-NG	PVI-12.0-I-OUTD-S1-CAN-480-NG	PVI-12.0-I-OUTD-S1-CAN-600-NG	
With AC and DC switches and DC fuses	PVI-12.0-I-OUTD-S2-US-480-NG	PVI-12.0-I-OUTD-S2-CAN-480-NG	PVI-12.0-I-OUTD-S2-CAN-600-NG	

\*Capability enabled at nominal AC voltage and with sufficient DC power available  
Information in this document is subject to change without notice



## Further information

For more information on ABB products and services for solar applications, navigate to [www.abb.com/solarinverters](http://www.abb.com/solarinverters)

# Contact us

[www.abb.com/solarinverters](http://www.abb.com/solarinverters)

PVI-10-12-I-OUTD-US/CAN Product Manual  
BCG.00542.1\_AA (NA REV 1.1)  
© Copyright 2014 ABB. All Rights Reserved.